



LNG Fuelled Ships

IENE Energy & Shipping

TERIAKIDIS G.
2013-03-06



ΙΝΣΤΙΤΟΥΤΟ ΕΝΕΡΓΕΙΑΣ
ΝΟΤΙΟΑΝΑΤΟΛΙΚΗΣ ΕΥΡΩΠΗΣ

MANAGING RISK



Topics

- Current situation in shipping
- LNG: Why ?
- LNG fuelled vessels
- Propulsion and tanks
- Supply of LNG fuel
- Examples of bunkering
- Conclusions



Current situation

Demanding regulatory timeline

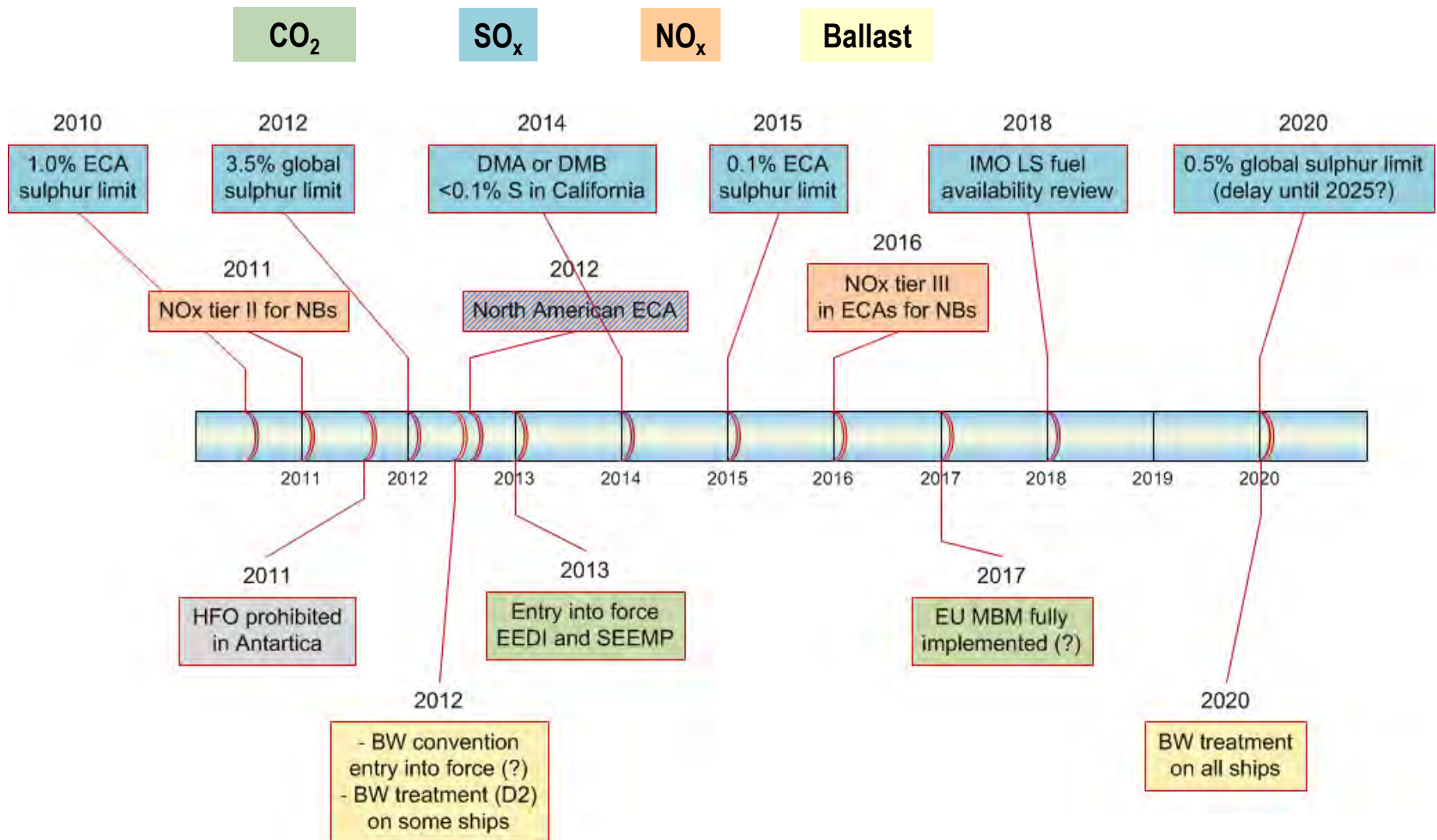

What should owners do ?



Environmental requirements are on the rise

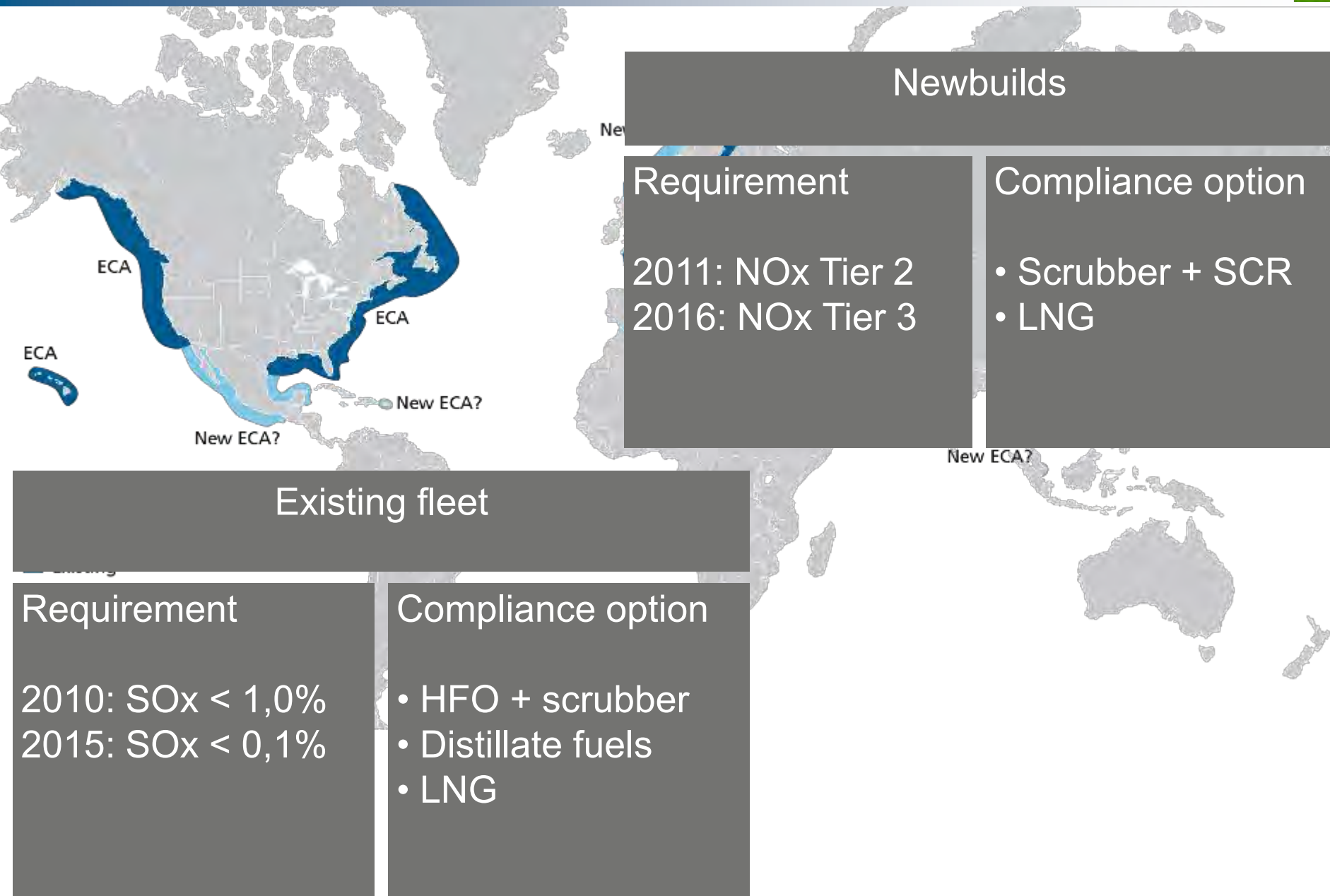

Ok... but why LNG ?

The NOx fund: The alternative to governmental NOx tax!

NOx-Tax 2700 USD/ton NOx



No NOx-Tax



670 USD/ton NOx



M USD

NOx-Fund

■ Fund's finances:

- Oil and gas producers pay to the fund 1 850 USD per ton NOx emitted
- All other emitters pay to the fund 670 USD per ton NOx emitted (30'-50' USD/year)
- Total disposable funds for NOx reducing measures: 300 M USD

- The fund has been prolonged until 2018 due to its recognized success.

Growing predicted price disparity oil /gas

Oil and natural gas prices

2008 dollars per million Btu

Current LNG fuel sales price in Norway →

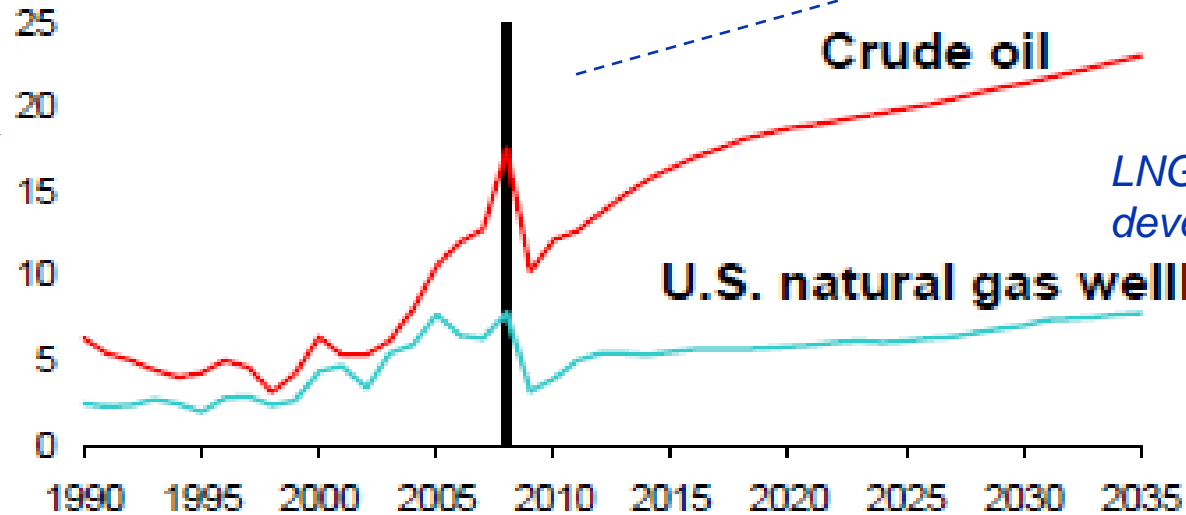

Increasing distillate prices (demand/production)?

LNG fuel price development?

Source: EIA

Cost of fuel is the key parameter

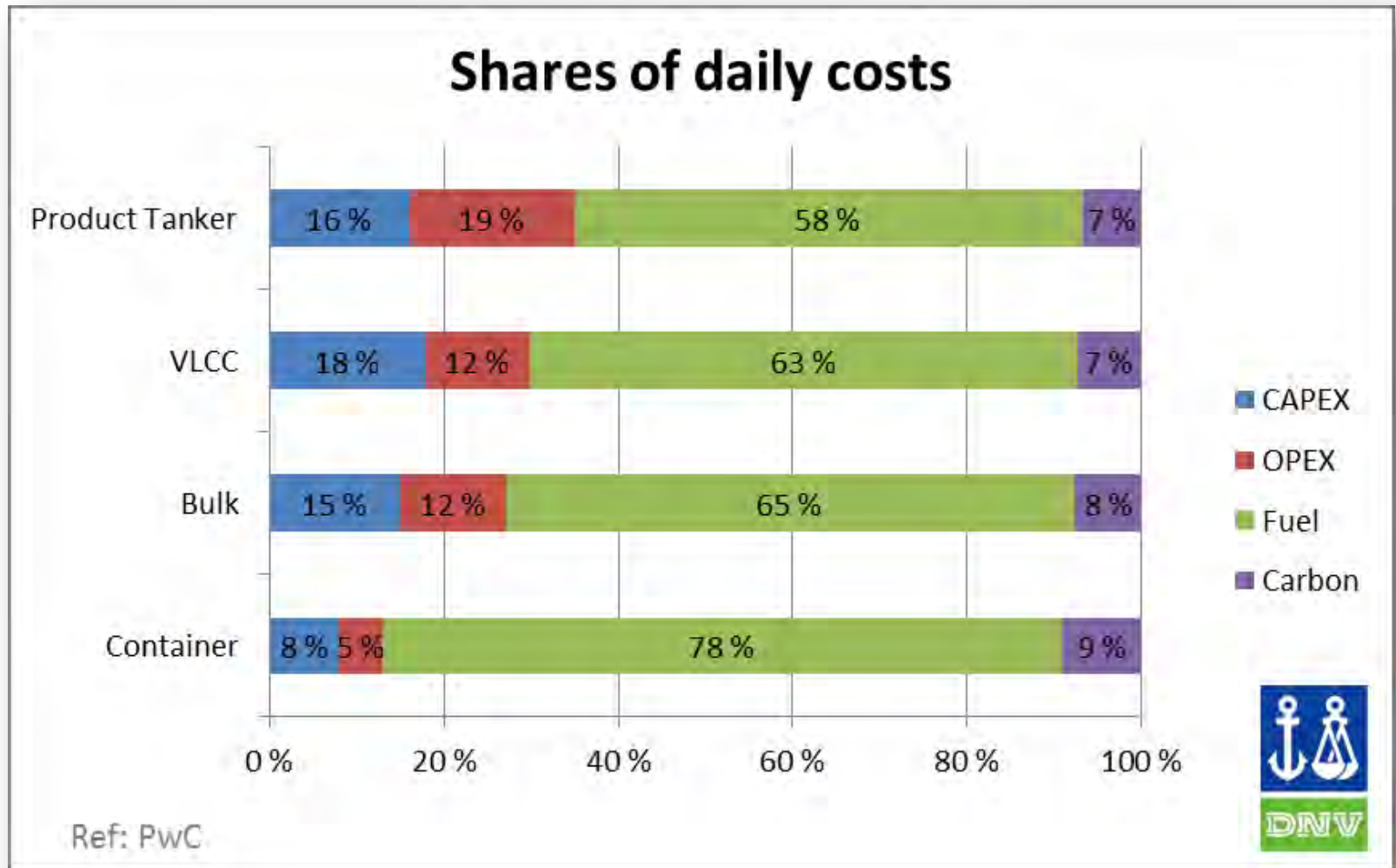

Ref: PriceWaterhouseCoopers and US Energy Information Administration

So... are there any such ships ?

Situation prior to 2000

- CNG driven ships in Russia, Netherlands, US, Canada, Australia
- Gas engines installations for maritime/ offshore use (mainly FPSOs)
- LNG/LPG Carriers
 - gas propulsion, gas piping, gas tanks, materials, testing and so on



2000...*GLUTRA*

■ The LNG fuelled car and passenger ferry Glutra



- Gas engines located in 4 separate machinery spaces
- In full operation since January 2000- excellent performance

Photo: Harald Valdehaug

The technology is available and in use today...

2020 guess:
1000

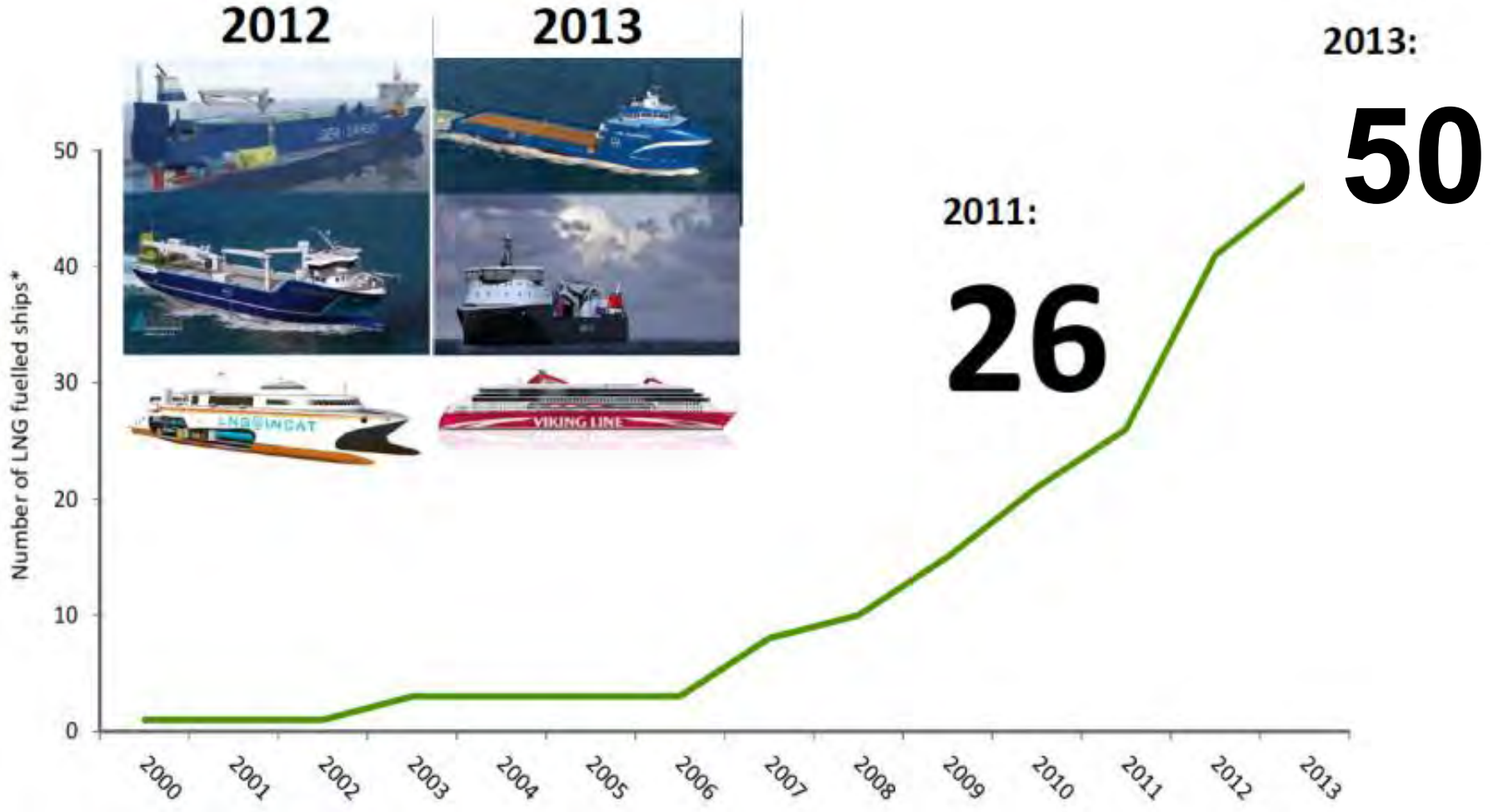

Examples



Examples



The LNG fuelled fleet in service and on order

Ships in operation

Year	Type of vessel	Owner	Class	Engine type
2000	Car/passenger ferry	Fjord1	DNV	Gas
2003	PSV	Simon Møkster	DNV	DF
2003	PSV	Eidesvik	DNV	DF
2006	Car/passenger ferry	Fjord1	DNV	Gas
2007	Car/passenger ferry	Fjord1	DNV	Gas
2007	Car/passenger ferry	Fjord1	DNV	Gas
2007	Car/passenger ferry	Fjord1	DNV	Gas
2007	Car/passenger ferry	Fjord1	DNV	Gas
2008	PSV	Eidesvik Shipping	DNV	DF
2009	PSV	Eidesvik Shipping	DNV	DF
2009	Car/passenger ferry	Tide Sjø	DNV	Gas+Diesel
2009	Car/passenger ferry	Tide Sjø	DNV	Gas+Diesel
2009	Car/passenger ferry	Tide Sjø	DNV	Gas+Diesel
2009	Patrol vessel	REM	DNV	Gas+Diesel
2009	Car/passenger ferry	Fjord1	DNV	Gas+Diesel
2010	Patrol vessel	REM	DNV	Gas+Diesel
2010	Car/passenger ferry	Fjord1	DNV	Gas+Diesel
2010	Patrol vessel	REM	DNV	Gas+Diesel
2010	Car/passenger ferry	Fjord1	DNV	Gas+Diesel
2010	Car/passenger ferry	Fosen Namsos Sjø	DNV	Gas+Diesel
2011	PSV	DOF	DNV	DF
2011	Chemical tanker	Tarbit Shipping	GL	DF
2011	Car/passenger ferry	Fjord1	DNV	Gas
2011	PSV	Solstad Rederi	DNV	DF
2011	Inland/port tanker	Argonon/Deen	LR	DF

Confirmed orderbook

Year	Type of vessel	Owner	Class	Engine type
2012	General Cargo	Nordnorsk Shipping	DNV	Gas
2012	PSV	Olympic Shipping	DNV	DF
2012	PSV	Eidesvik	DNV	DF
2012	PSV	Eidesvik	DNV	DF
2012	Ro-Ro	Sea-Cargo	DNV	Gas
2012	Ro-Ro	Sea-Cargo	DNV	Gas
2012	High speed RoPax	Buquebus	DNV	DF Turbine
2012	PSV	Island Offshore	DNV	Gas+Diesel
2012	PSV	Island Offshore	DNV	Gas+Diesel
2012	PSV	REM	DNV	DF
2013	General Cargo	Eidsvaag		Gas
2013	Ro-Ro	Norlines	DNV	Gas
2013	Ro-Ro	Norlines	DNV	Gas
2013	RoPax	Torghatten Nord	DNV	Gas
2013	RoPax	Torghatten Nord	DNV	Gas
2013	RoPax	Torghatten Nord	DNV	Gas
2013	RoPax	Torghatten Nord	DNV	Gas
2013	RoPax	Torghatten Nord	DNV	Gas
2013	RoPax	Viking Line	LR	DF
2013	PSV	Harvey Gulf Int. Marine	ABS	DF
2013	PSV	Harvey Gulf Int. Marine	ABS	DF
2013	Patrol vessel	Finish Border Patrol		DF
2013	Car/passenger ferry	Society of Quebec ferries		DF
2014	Car/passenger ferry	Society of Quebec ferries		DF

Planned conversion

Year	Type of vessel	Owner	Class	Engine type
2011	Car/passenger ferry	Fjord1	DNV	Gas

LNG Fuelled SI DF= Dual Fuel engine Gas+Diesel= Separate LNG and diesel fuelled engines Gas= Lean burn (mono fuel) LNG engine

2013-03-06

© Det Norske Veritas AS. All rights reserved.

Propulsion & tanks

Propulsion systems and fuel combinations

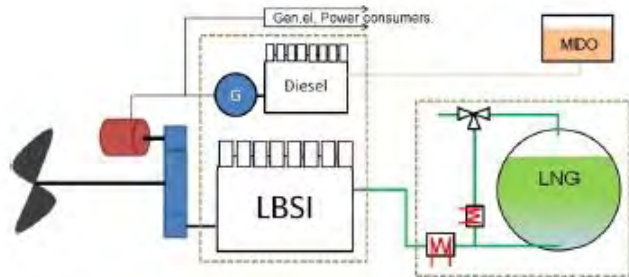
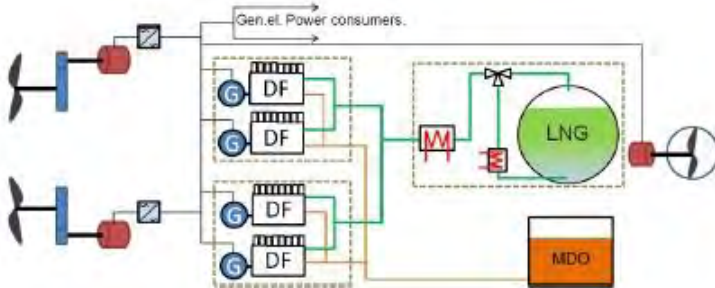
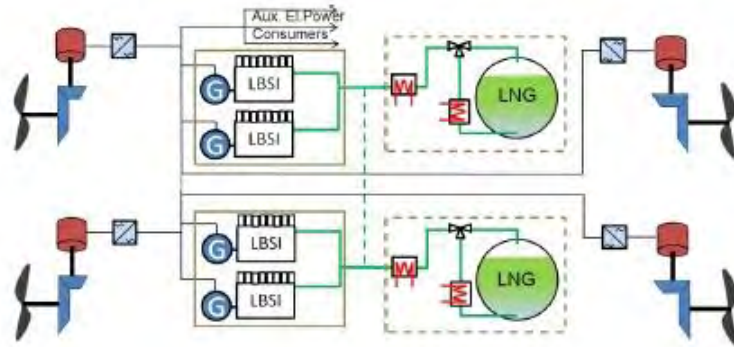

Test of ME GI engine and fuel supply of HHI in November 2012



Source: HHI

Tank location

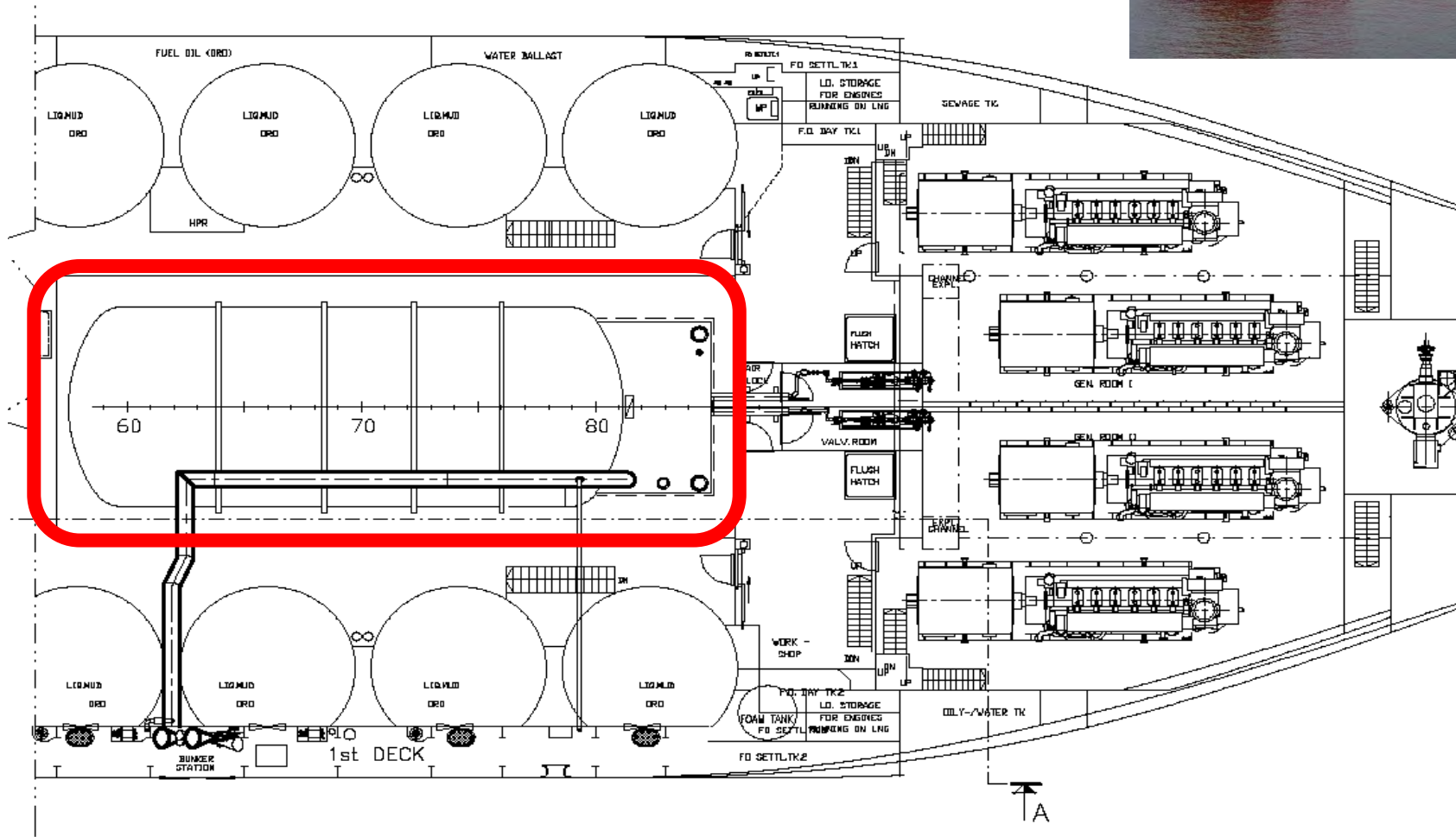

Coast guard vessels- delivered 2009/2010

- Power take in from LNG fuelled engines, to be used in normal operation
- Diesel engine to be used as backup, and for full speed operation

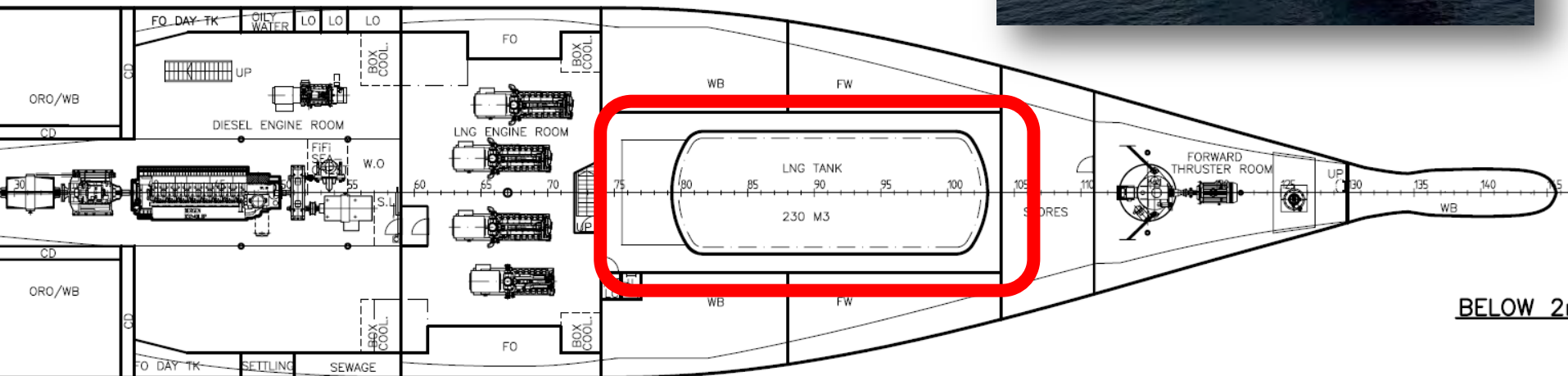

Supply of LNG fuel

Current and forecast of global LNG bunkering infrastructure by 2020



 Existing  Planned (*Feasibility study, risk study, proposed locations, pending approval*)  Proposed (*currently being discussed*)

* See detailed map

LNG Bunkering supply in Europe by 2020

Existing

1. Florø
2. CCB
3. Halhjem
4. Snurrevarden
5. Risavika

Proposed

22. Gothenborg
23. Pori
24. Turku
25. Sillamäe
26. Helsinki
27. Paldiski
28. Riga
29. Swinoujscie
30. Lubeck
31. Rostock
32. Helsingborg
33. Copenhagen
34. Aarhus
35. Aberdeen
36. Dunkerque
37. Marseilles
38. Barcelona
39. Algeciras

Planned

6. Bodø
7. Mongstad
8. Øra
9. Lysekil
10. Porvoo
11. Stockholm
12. Tallin
13. Klapeida
14. Hirtshals
15. Brunsbüttel
16. Hamburg
17. Rotterdam
18. Antwerp
19. Zeebrugge
20. Ghent
21. Vestbase

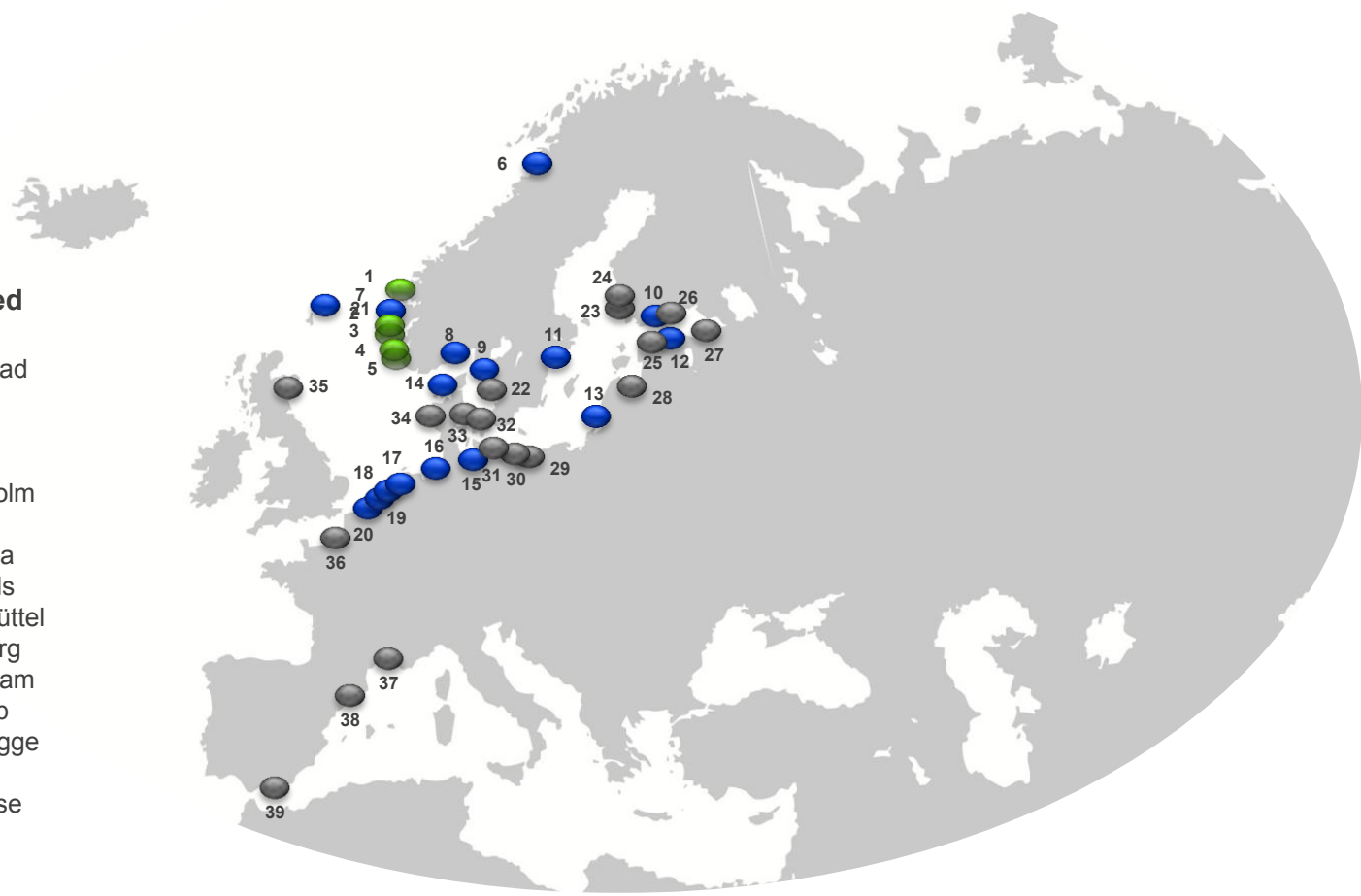

 Existing

 Planned (*Feasibility study, risk study, proposed locations, pending approval*)

 Proposed (*currently being discussed*)

Bunkering alternatives in Norway



Bunkering from trailer



Ship bunkering terminal,
supply vessel



Ship bunkering terminal,
ferry

Ship to ship (STS) operation



LNG transfer by hoses

Purpose built LNG distribution and bunker



Pictures courtesy Veka-Group

Shell to Boost LNG Fuel Access in Louisiana, Ontario

BY GCAPTAIN STAFF ON MARCH 5, 2013

 Like  Tweet 



LNG-powered Offshore Supply Vessels like this one will support Shell's operations in the Gulf of Mexico. Image courtesy of Harvey Gulf International Marine.

Shell added that it has a memorandum of understanding with Edison Chouest Offshore companies (ECO) to supply LNG fuel to marine vessels that operate in the Gulf of Mexico and to provide what is anticipated to be the first LNG barging and bunkering operation in North America at Port Fourchon, Louisiana. The LNG transport barges will move the fuel from the Geismar production site to Port Fourchon where it will be bunkered into customer vessels.

Examples of bunkering

Bunkering



LNG bunkering station, Ågotnes

- Jetty with bunkering equipment
- Shore based LNG tank



Onshore tank arrangement



LNG piping
arranged
underground

Jetty/ LNG piping



LNG transfer equipment

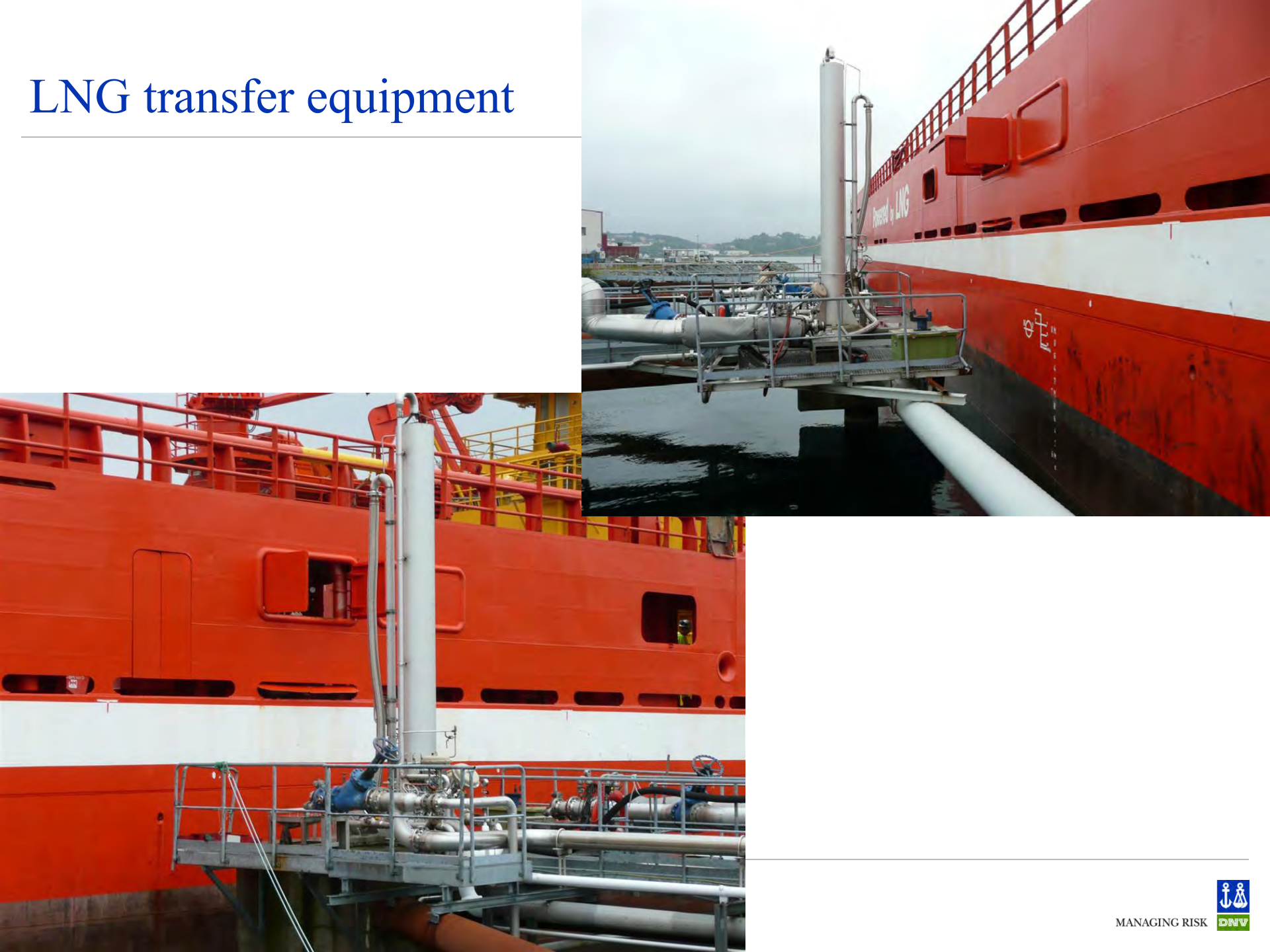

Supervision from ECR (2)

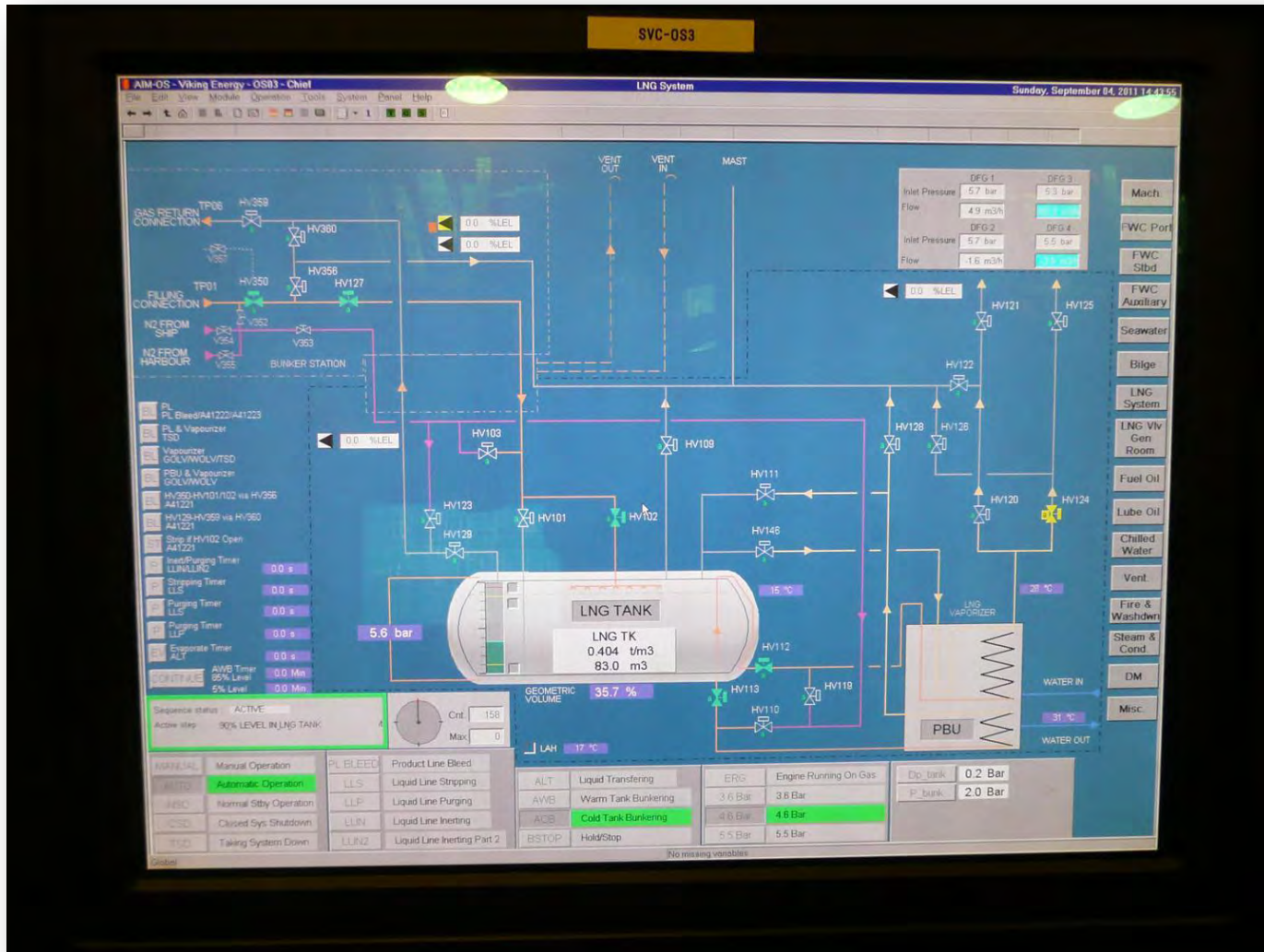

Ongoing transfer



LNG flange



Halhjem: 1000 m³ tanks for bunkering



Conclusions

Conclusions

- Challenging years ahead
- Target: Vessel emissions
- Various solutions
 - Scrubbers
 - SCRs
 - LNG

LNG

- Small coastal vessels:
 - steady increase
- Larger vessels:
 - Region of trading
 - Frequency of trading
 - Space !
 - Case to case



Safeguarding life, property and the environment

www.dnv.com



MANAGING RISK