



INSTITUTE OF ENERGY
FOR SOUTH-EAST EUROPE

“Prospects for the Electric Vehicle Market and Business opportunities with special reference to SE Europe and Greece”

IENE Working Paper No24



Athens, September 2018

“Prospects for the Electric Vehicle Market and Business opportunities with special reference to SE Europe and Greece”

Authors:

Alexandros Perellis, Research Associate, IENE

Costis Stambolis, Executive Director, IENE

Institute of Energy for SE Europe (IENE)
3, Alexandrou Soutsou, 106 71 Athens, Greece
tel: 0030 210 3628457, 3640278 fax: 0030 210 3646144
web: www.iene.gr, e-mail: secretariat@iene.gr

Copyright ©2018, Institute of Energy for SE Europe

All rights reserved. No part of this study may be reproduced or transmitted in any form or by any means without the prior written permission of the Institute of Energy for South East Europe. Please note that this publication is subject to specific restrictions that limit its use and distribution.

“Prospects for the Electric Vehicle Market and Business opportunities with special reference to SE Europe and Greece”

September 2018

This paper summarizes the findings and conclusions of IENE’s Study on the “Prospects for the Electric Vehicle Market in Greece and Business Opportunities” (IENE Study M47)

This IENE Study Project was financially supported by a number of companies and organizations whose valuable contribution and support is acknowledged herewith with great thanks. The following companies acted as sponsors of the present study;



Disclaimer

This document contains the best opinion of the contributors at the time of issue and does not necessarily represent IENE’s official position. Neither IENE nor the sponsor company offer any warranty or guarantee regarding the accuracy of any forecasts, estimates or analyses contained in this report. The contributors, IENE and the sponsor company are not responsible for any liability in association with this content.

Table of Contents

1. Introduction	5
2. Technology.....	6
A. Vehicle Technology.....	6
B. Battery Technology.....	8
C. EV Efficiency and Energy Savings.....	11
D. Utility Electric Vehicles	13
3. EV Market.....	14
A. Present of Global EV Market	14
B. Global Trends and the Future of EV Market	25
C. Greece’s EV Market	29
E South East Europe’s EV Markets	32
4. Electric Mobility Infrastructure and Charging Stations	33
A. Current Charging Technology and Available Charging Infrastructure Worldwide	33
B. Charging and Safety Issues	36
C. The Impact of EV Adoption on Power Generation and Distribution.....	37
D. Smart Charging Strategies	38
E. Use of EVs in an Urban Environment: The Case of Paris and other business models	39
F. EV Charging considerations for Greece	39
5. Cost Analysis of Production and Use of EVs	41
6. Environmental impact of EV introduction	43
A. Environmental Benefits.....	43
B. EVs and the Decarbonization of on-road transport	48
7. Electric Vehicle introduction and Economic Repercussions in South East Europe .	49
Bibliography	50

1. Introduction

The combination of various parameters which have matured at global level, as well as IEA's scenarios for energy demand and consumption reflecting COP21's commitments for climate change mitigation, have helped our understanding and needs for energy transition. The adoption of the 2DS¹ scenario is a milestone for the whole energy sector underlining fundamental changes in the future approach of sectorial energy consumption including transport. These policies focus on the adoption of electric vehicles' (EVs) as a pillar for the support of global action for the decarbonization of the energy and transport sector. Hence, the study of EV development in Greece and in other selected countries in South East Europe is necessary for the formulation of both national and regional planning for energy use in transport. Such policies are to be pursued in accordance with recommendations by prominent international organizations. Consequently, individual research, aiming towards the reform of the operational objectives of the relevant local industry, becomes crucial towards the formulation of those strategies. The Petroleum Industry, Power Generation companies, Power Distribution Companies, the Vehicle and Battery Industry should all adapt to the new environment from the perspective of energy transition promotion and decarbonization of the transport sector.

The study places the development of EVs in the future landscape, where in accordance to the 2DS scenario, electrification and high penetration of renewable energy resources will shape the main strategy for the formulation of the future of the global energy mix. In such a framework, it is expected that power producers will be challenged to reduce their carbon footprint by promoting the transition to less carbon intensive fuels such as natural gas and RES, with the gradual phasing out of coal plants. Towards this direction some of the biggest power producers, which were traditionally involved in power generation, using oil and coal, are now switching to low carbon technologies and RES. In this framework the introduction of EVs will provide an extra step towards transport decarbonization, thus enhancing mobility, which will be supported by low carbon intensive electricity.

The adaptation of EV technology to the mobility needs of consumers is considered most crucial for the achievement of the new energy mobility transition. The rapidly improving Battery Technology, in terms of cost and energy density, and the diffusion and development of EV charging technology will play a vital role towards this direction. Power grid and power generation operations will also have to adjust their

¹ 2DS Scenario refers to IEA's scenario for restructuring the global human activity in order to reduce the effect of climate change to a 2°C raise of the average global temperature by 2100. The 2DS lays out an energy system deployment pathway and an emissions trajectory consistent with at least a 50% chance of achieving such climate change mitigation effect. 2DS limits the total remaining cumulative energy-related CO₂ emissions between 2015 and 2100 to 1 000 GtCO₂. (Source: IEA)

capacities to facilitate the electrification of the transport sector. The restructuring, enhancement and expansion of the power distribution network are important since they will be necessary for securing the system’s resilience in high EV penetration markets. This will constitute one of the great challenges of the system from an economic standpoint, with a large number of parameters at play, each of them crucial for the viability of the system from a socioeconomic perspective.

The main scope of the present Working Paper is to inform about the global developments in the EV market and technology as described above, but also to assess the dynamics of EV market development. The study focuses on Greece as a reference country and expands in other South East European countries. It is important to record and describe the crucial technical and non-technical parameters involved in EV technology and its future development as well as the boundaries of the EV adaptation to the present mobility market.

2. Technology

A. Vehicle Technology

The advantages of EVs in comparison to internal combustion engine (ICE) vehicles can be listed as following: (a) the decarbonization of transport sector with the utilization of power generated by RES. (b) The less primary energy utilization for road transport (63.3% when Energy is coming from renewable, 8.4% when is generated by gas turbines²), (c) the overall high energy efficiency, reaching up to 81% of the total electrical energy stored in the EV battery transformed to mechanical in comparison to the 14% of a conventional ICE vehicle³, (d) the elimination of the noise pollution resulting from the engine operation, (e) the low operation cost due to the lower cost of electricity in comparison to petrol, (f) the low maintenance cost resulting from the lower amount of moving parts.



Figure 1 EV Operating Energy Flow and Efficiency Diagram (Source: Abdul-Hat et al.)

² N.O. Nylund, (2013), “Mobility: Technology Priorities and Strategic Urban Planning”

³ M. Abdul-Hak et al. (2011) “Predictive Intelligent Battery Management System to Enhance the Performance of Electric Vehicle”

The disadvantages of EVs include (a) The limited driving range, which is negatively affected by (b) the lack of publicly available charging infrastructure, (c) The charging time which is spanning from 1 to 40 hours, depending on the power output of the available charging infrastructure and the battery size of the EV⁴, and (d) the high acquisition cost of EVs due to low technology maturity which can be identified in ongoing production ramp ups and adjustments, which are present today in the EV industry.

Most common EVs are Battery electric Vehicles (BEVs), Plug in Hybrid Electric Vehicles (PHEVs) and Fuel Cell Electric Vehicles (FCEVs), which come in various drivetrain architectures, enabling different mobility features and inside-the-vehicle energy management. BEVs have a purely electric drive and consist of an electric battery for energy storage, the DC/DC converter, which adjusts the voltage of the electric current provided to a 2 quadrant inverter or a 4 quadrant bidirectional inverter with a dedicated power electronics controller, which controls the power provided to (and from, in case of regeneration capability, i.e. 4 quadrant inverter) the electric motor. The 4 quadrant inverter utilizes inertia for regeneration (recharging) during deceleration and braking. The battery, which has a larger capacity than in the same type of PHEVs, is normally recharged through a plug and a battery charging unit, which can either be carried on board or fitted at the charging point. The power electronics controller regulates the power supplied to the motor and hence it controls the vehicle speed forwards and backwards as well as the system of regenerative braking (frictionless deceleration) as mentioned above.

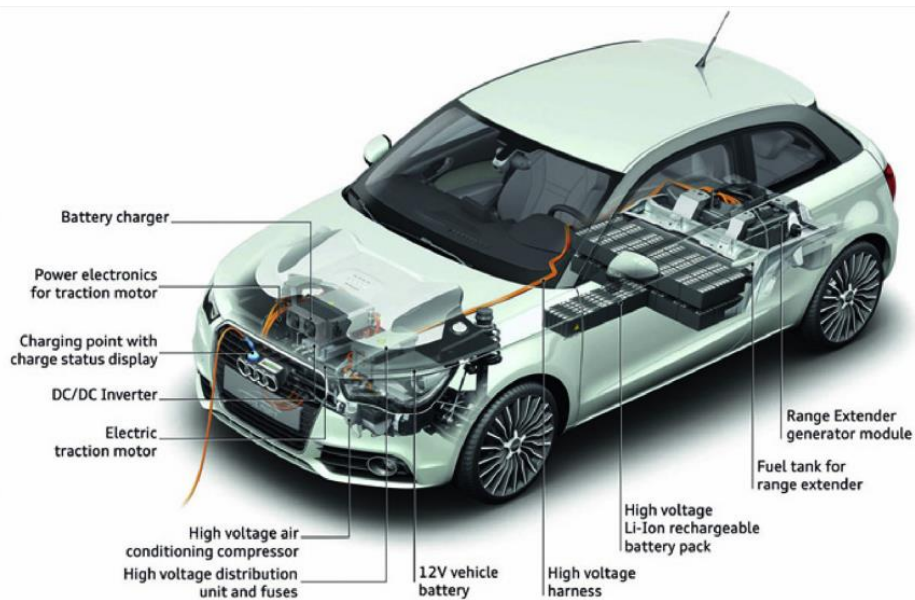

Figure 2 Illustration of the electrical traction system of a Plug-in Hybrid Electric Vehicle (PHEV)

The range problem of BEVs is addressed successfully with another vehicle configuration similar to the one of BEV, but with the addition of an internal

⁴ Data provided by Clipper Creek

combustion engine (ICE) to provide the powertrain with energy when the discharge capacity of the onboard battery is depleted. The solutions, promoted by PHEV configuration, either use the ICE to provide generated energy to the battery, which fall as mentioned to the extended range electric vehicles (EREV) category or directly to the electric motor⁵. The ICE is utilized when the PHEV's battery reaches a specific state of charge (SOC). Typically the fuel consumption in such drivetrains is significantly less than conventional gas vehicles. In a typical PHEV like BMWi3 REX the test-estimated fuel consumption by the manufacturer is 6l / 100 km ⁶but this can reach very low levels when the vehicle in its everyday schedule doesn't exceed its electric range⁷.

Fuel cell electric vehicles (FCEVs) are all-electric vehicles; hence they share a similar powertrain with BEVs with the difference that its energy source is a fuel cell stack. The FCEVs are powered by hydrogen induced electrolysis, with water and heat being the only byproducts of this process, hence FCEVs are zero emission vehicles. The polymer electrolyte membrane fuel cell (PEMFC) is the most preferred fuel cell due to its high power density, low operating temperature (60°C – 80°C) and low corrosion in comparison to other fuel cell solutions⁸. Other types of FCs include direct methanol fuel cells (DMFC), proton exchange membrane fuel cells (PEMFC), alkaline electrolyte fuel cells (AFC), phosphoric acid fuel cells (PAFC), molten carbonate fuel cell (MCFC) and solid oxide fuel cells (SOFC)⁹.

B. Battery Technology

A battery is a device which transforms the chemical energy content in its active material, directly to electrical energy, through an electrochemical oxidation-reduction (redox) reaction. Oxidation-reduction reactions are a combination of two processes: oxidation, in which electrons are lost, and reduction, in which electrons are gained. This type of reaction utilizes the ion flow between the electrodes through the electrolyte to create opposite charge between the electrodes and thus enable the transfer of electrons from one material to another through an external electric circuit. The electrochemical processes occurring in rechargeable batteries can be reversed by providing electrical energy to the battery. In the recharging process the flow of electrons between the anode and the cathode is reversed returning the electrodes to their original state. A battery consists of one or more battery elements connected in series or in parallel to regulate the voltage output

⁵ D. Herron, (2018), "The plug-in hybrid versus extended range electric vehicle debate"

⁶ *The Car Guide*, (2017), "BMW i3 Range Extender Specifications"

⁷ *Spritmonitor.de*, "Consumption: BMW - i3", [Retrieved on Jan 2018]

⁸ C. C. Chan, (2007), "The state of the art of electric, hybrid, and fuel cell vehicles."

⁹ G. Bromaghim et al. , (2010) "Hydrogen and fuel cells: The U.S. market report."

and the battery capacity. Specifically, the battery element contains: **(1)** The Anode or the negative electrode which releases electrons in the external circuit and is the one that sustains oxidation (loses electrons) during the electrochemical reaction. **(2)** The Cathode or the positive electrode which receives electrons from the external circuit and sustains reduction (gains electrons) during the electrochemical reaction. **(3)** The Electrolyte, which provides a mean for transferring electrons inside the battery element (from the anode to the cathode).

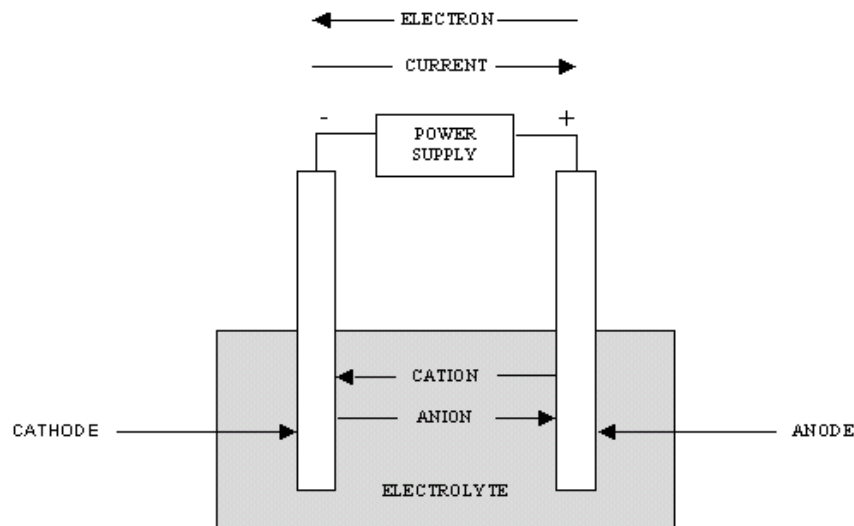

Figure 3 recharging a battery cell

Battery Materials

Anode material: The anode material must be (a) effective as reductive mean, meaning it should be effective in causing reduction, while it gets oxidized. (b) It must also have high ampere hour performance (Ah/g)¹⁰, (c) must be conductive, (d) stable, (e) being constructed with a comprehensive, convenient procedure, (f) being abundant with a low cost. Nowadays, there are various highly capable materials to be used as a negative electrode including Hydrogen, Graphite, Zinc, Lithium, Titanium etc.¹¹

Commercially the most commonly used anodes in EV batteries are made of predominantly graphite (G) or lithium titanium oxide (LTO). Ongoing research in the anode field lead to, Toshiba corporation announcing, in October 2017, a next generation lithium-ion EV battery featuring a new anode material, lithium titanium niobium oxide (LTNO), which stores lithium ions more efficiently by using a

¹⁰ A practical unit for measuring electric charge, which expresses the amount of electric charge, transferred through a conductor, when the electric current has amperage of 1 A during a period of 1 hour.

¹¹ A. Eftekhari, (2017), "Low voltage anode materials for lithium-ion batteries"

proprietary method of synthesizing and processing. Moreover, LTNO anode is much less likely to experience lithium deposition during rapid discharging or recharging in cold conditions, causing battery degradation and internal short circuits. In addition, it provides twice the capacity of the standard graphite anode, realizing driving range boost to 320km and is able to maintain 90% of its initial capacity after 5000 cycles at very high charging rates, achieving safe full battery charging on 6 minutes¹². The anode research for EV batteries is currently focused on the adaptation of materials with high theoretical capacity like Si, which has a tenfold capacity in comparison to graphite.

Cathode material: The cathode material must be: (a) effective as an oxidative mean, meaning to cause oxidation while it gets reduced, (b) stable when in contact with the electrolyte. (c) It must meet a required voltage of operation. Oxygen for the oxidation might come from air entering the battery cell as it happens in zinc-air batteries. The Cathode materials, most typically metal oxides, which show competitive oxidation capabilities, high cell voltage induced capacities and are highly utilized in the EV battery market are lithium cobalt oxide (LCO), lithium nickel cobalt manganese oxide (NMC), lithium nickel cobalt aluminum oxide (NCA), lithium manganese oxide (LMO), or lithium iron phosphate (LFP).

One of the most commonly used cathode material, lithium nickel cobalt manganese oxide LiNiMnCoO_2 (NMC), is a novel lithium insertion electrode material, in which the manganese (Mn) doping increases significantly the thermal stability achieved by its low internal resistance, which is induced by its spinel molecular structure, but offers low specific energy. NMC cathodes can have various architectures intended to be used in either energy or power cells. Their overall performance, high specific energy and low self-heating rate make them a very good candidate for EV applications. The active cathode materials, nickel, manganese and cobalt can easily be blended to be suited in various automotive powertrains that need frequent cycling. The cathode combination is typically one-third nickel, one-third manganese and one-third cobalt, also known as 1-1-1 ($\text{LiNi}_{0.33}\text{Mn}_{0.33}\text{Co}_{0.33}\text{O}_2$). This offers a unique blend that also lowers the raw material cost due to reduced cobalt content. Another successful combination is NCM with 5 parts nickel, 3 parts cobalt and 2 parts manganese.^{13 14}

Another widely used EV battery cathode material, Lithium Nickel Cobalt Aluminum Oxide (LiNiCoAlO_2)(NCA), is an Aluminum doped Lithium nickel cobalt oxide (LNCO), in which the Al doping is found to be very effective in suppressing the cell impedance rise by stabilizing the charge-transfer impedance on the cathode side. It also shows

¹² *Toshiba*, (2017), "Toshiba Develops Next-Generation Lithium-ion Battery with New Anode Material"

¹³ http://batteryuniversity.com/learn/article/types_of_lithium_ion

¹⁴ *Sigma-Aldrich*, "Lithium nickel manganese cobalt oxide"

excellent electrochemical performance with high specific capacity and good cycling and thermal stability. Although NCA batteries offer high specific energy, good specific power and a long lifespan, they lack on safety, as high charge is likely to cause thermal runaways¹⁴. Research and development performed by Dalhousie University and Tesla Canada Industrial Research on the cathode materials has produced a new cathode aluminum coating technology that can extend the cycle life of high voltage NMC cathodes by 100%. Upon testing, it only showed signs of degradation under harsh conditions, maintaining approximately 95% of the cells original capacity after 1200 cycles at moderate temperature. The cells showed also higher energy density and better tolerance to fast charging than NMC, while the extended cycle life can propel an EV battery to last for over 450,000km^{15 16}.

Electrolyte material: The material selected for electrolyte must have: (a) High ion conductivity but not be electrically conductive, because electric conductivity would cause constant internal short-circuits. (b) The electrolyte must not react with the electrodes and (c) must not be affected by temperature changes, while (d) being safe and (e) produced in low cost.

Table 1 Commercial EV Batteries' Chemistry and Specifications (Source: influitenergy)

Cell Manufacturer	Anode/ Cathode Chemistry	Capacity (Ah)	Cell Voltage, (V)	Energy Density, (Wh/L)	Energy Density, (Wh/kg)	EV Manufacturer Model
AESC	G/LMO-NCA	33	3.75	309	155	Nissan/ Leaf
LG Chem	G/NMC-LMO	36	3.75	275	157	Renault/ Zoe
Li-Tech	G/NMC	52	3.65	316	152	Daimler/ Smart
Li Energy Japan	G/LMO-NMC	50	3.7	218	109	Mitsu-bishi/ i-MiEV
Samsung	G/NMC-LMO	64	3.7	243	132	Fiat/ 500
Lishen Tianjin	G/LFP	16	3.25	226	116	Coda/ EV
Toshiba	LTO/NMC	20	2.3	200	89	Honda/ Fit
Panasonic/ Tesla	G/NCA	3.1	3.6	630	265	Tesla/ X, S, 3

C. EV Efficiency and Energy Savings

Nowadays, with the development of new EV technologies, considerable advancements in powertrain efficiency, power electronics, aerodynamics, and lightweight technologies are driving the overall improvement of EV energy efficiency.

¹⁵ E. Timofeeva, (2017), "The Spectrum of EV Battery Chemistries"

¹⁶ F. Lambert, (2017), "Tesla battery researcher says they doubled lifetime of batteries in Tesla's products 4 years ahead of time"

Various marketed EV models employ these strategies to improve their efficiency. One of the most notable achievements towards this direction is the EV battery technology advancements developed by the partnership of GM with LG Chem, as demonstrated by the 2016 Chevrolet Volt. Specifically, the consortium managed to improve the individual cell capacity in such a way as to reduce by 33% the number of cells in the Volt (2016) model in order to achieve an increase of 8% or +1.47kWh in total battery capacity in comparison with its predecessor. Consequently, GM estimated that its new model is 45kg lighter and 12% more energy efficient^{17 18}.

Table 2 Estimated energy consumption of common EVs. (source: Battery University/ Cadex Electronics Inc.)¹⁹

EV model	Battery Capacity	Range km (mi)	Wh/km (mi)
BMW i3 (2016)	22kWh	135km (85)	165 (260)
GM Spark	21kWh	120km (75)	175 (280)
Fiat 500e	24kWh	135km (85)	180 (290)
Honda Fit	20kWh	112km (70)	180 (290)
Nissan Leaf (2016)	30kWh	160km (100)	190 (300)
Mitsubishi MiEV	16kWh	85km (55)	190 (300)
Ford Focus	23kWh	110km (75)	200 (320)
Smart ED	16.5kWh	90km (55)	200 (320)
Mercedes B	28kWh (31.5)*	136km (85)	205 (330)
Tesla S 60	60kWh	275km (170)	220 (350)
Tesla S 85	90kWh	360km (225)	240 (380)

* Driving range limited to 28kWh; manual switch to 31.5kWh gives extra 16km (10 mile) spare

Notable development in the automaker industry is the rapid improvement of battery energy density. The proven lithium manganese oxide (LiMn₂O₄) with a blend of lithium Nickel Manganese Cobalt Oxide (LiNiMnCoO₂) prismatic battery pack technology, used by many successful EV models such as the Nissan Leaf and BMW i3, offers a moderate energy density and it is expected soon to be compromised by more advanced technologies. Towards this direction, Tesla Motors diversified its battery technology adopting the use of Lithium Nickel Cobalt Aluminum Oxide (LiNiCoAlO₂) in its “18650 cell” which can deliver an impressive specific energy of 3.4Ah per cell or 248Wh/kg. However, the large 90kWh battery of the Tesla model S (2015), which is employed to extend its driving range at the impressive 424km, weighs 540kg increasing significantly its energy consumption to 238Wh/km making it one of the most energy inefficient EV models in the market.

On the other hand, BMW i3 is one of the lightest EVs in the market, hence one of the most energy efficient with consumption of 160 Wh/km. The vehicle employs a

¹⁷ General Motors, (2015), “Chevrolet Introduces All-New 2016 Volt”

¹⁸ P. Slowik, et al. (2016), “Assessment of next-generation electric vehicle technologies.”

¹⁹ The common EVs presented in Table 6 are reference to the EV models of 2016. Although in latter chapters of this study more recent models have been used as a reference

LNO/NMC battery which has moderate energy density of 120Wh/kg and in combination with its midsize 22kWh battery pack it provides a very limited battery range of 130-160km. To compensate BMW i3's limited range, the manufacturer offers a PHEV version of the model which achieves a longer driving range with the use of the additional gasoline engine (range extender), but has reduced energy efficiency due to its extra weight.

Energy efficiency also refers to the vehicle itself regardless to its powertrain. Studies showed that reduction of the weight of a passenger car of 10% can lead to decrease in energy requirement of 6-7%. Therefore, towards this direction, reduction of the chassis' weight is of great importance and can be achieved by size reduction and utilization of lighter materials, such as high-strength steels, aluminum alloys, magnesium alloys, titanium alloys, carbon fiber composites and nanocomposites²⁰.

One of the systems that compensate the relatively high energy consumption of heavy EVs is the regenerative braking. The larger the mass or the speed of the vehicle the higher its kinetic energy ($E = \frac{1}{2}mv^2$) and thus the more the energy that must be lost for its immobilization. A traditional braking energy recovery system recovers the part of the kinetic energy that is lost in the form of heat on the vehicle's brakes while slowing down. In EVs like Tesla Roadster the recovery would be different than in most conventional ICE vehicles. In EVs, where there is a single AC induction motor moving part, the engine doesn't experience compression while braking. Instead, the motor controller, in all times, including while in braking or driving mode, takes command of the existing torque of the motor, converting it into the appropriate 3-phase voltage and current waveforms to produce the commanded torque in the motor in the most efficient way. Torque command can be positive when driving or negative while braking returning charge to the battery.

D. Utility Electric Vehicles

Large utility vehicles face more efficiency challenges due to their large mass, rolling resistance and air drag due to the less aerodynamic shape. The engine efficiency in a conventional utility truck powertrain of 44% is relatively high and challenging for a cost competitive development of EV utility tractors. Moreover, the high mobility needs of such vehicles are in mismatch with the current available battery and charging technology. This mandates that with the maturity of EV market in terms of availability of charging infrastructure, the transportation and logistics sectors will also have to adapt by introducing idle time for tractors for either charging or battery swapping. For that reason fuel cell (FC) powertrain technologies might be more

²⁰ N.O. Nylund, (2013), "Mobility: Technology Priorities and Strategic Urban Planning"

feasible due to the large volumetric energy content of the FC²¹. Specifically, research by Gnann et al. (2017), questions the operational ability of BEVs to service the heavy duty vehicle segment of the fleet, pointing towards different considerations for long-haul logistics²².

3. EV Market

A. Present of Global EV Market

The Paris Climate agreement (COP21) initiated a late response of the market to the Climate Change challenges. The electrification of the energy demand along with the decarbonization of the energy generation is a first response to manmade Climate Change caused by the current carbon intensive energy sector as indicated by current policies worldwide. The electrification of the transport sector plays a large role in the decarbonization of the energy system, as long as the grid is powered by green energy. The Electric Vehicles (EVs) due to their rapid technological evolution are expected to reach parity with the petrol fueled ones during 2018 and eventually achieve a cheaper cost of ownership in 2022 even if the conventional ICE vehicles improve their fuel efficiency by 3.5% per year²³. It is now obvious that the vehicle market is shifting towards electricity.

In 2016 the global sales of plug in electric vehicles reached 753,000, 60% of which were battery-electric vehicles (BEVs). China was for the 2nd consecutive year the largest EV market in the world with more than 40% of the global sales, while Europe was the 2nd largest market with 215,000 EVs sold, which corresponds to 28,5% of the global market. United States were left in the 3rd place with 160,000 EVs sold. The market share of the plug in hybrid electric cars (PHEVs) is increased in comparison to the BEVs in EU and USA, while China is on the contrary oriented towards BEVs.

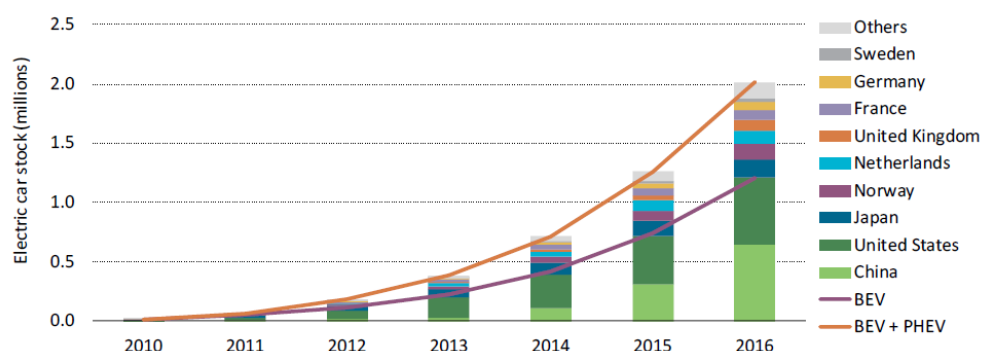

Figure 4 The Evolution of the global electric car stock, 2010-2016 (source: IEA)

²¹ Roland Bergen, (2017), "Development of Business Cases for Fuel Cells and Hydrogen Applications for Regions and Cities: FCH Heavy-duty trucks"

²² T. Gnann et al. (2017), "How to decarbonise heavy road transport?"

²³ D. Carrington, (2016), "Electric cars 'will be cheaper than conventional vehicles by 2022'"

Globally the EV sales showed growth of 40% in 2016. However, the growth declined from 70% in 2015 and it is the first time that it is below 50% since 2010. This raises the concern whether the 2DS scenarios' sales and stock objectives will be attained till 2025. However, the global economy is still on track with the 2DS scenario that predicts 35% of constant annual growth rate till 2025.

Table 3 List of OEMs' announcements on electric car ambitions (April 2017) (source: IEA)

OEM	Announcement
BMW	0.1 million electric car sales in 2017 and 15-25% of the BMW group's sales by 2025
Chevrolet (GM)	30 thousand annual electric car sales by 2017
Chinese OEMs	4.52 million annual electric car sales by 2020
Daimler	0.1 million annual electric car sales by 2020
Ford	13 new EV models by 2020
Honda	Two-thirds of the 2030 sales to be electrified vehicles (including hybrids, PHEVs, BEVs and FCEVs)
Renault-Nissan	1.5 million cumulative sales of electric cars by 2020
Tesla	0.5 million annual electric car sales by 2018 1 million annual electric car sales by 2020
Volkswagen	2-3 million annual electric car sales by 2025
Volvo	1 million cumulative electric car sales by 2025

According to Bloomberg New Energy Finance (BNEF), the best-selling battery-only EV (BEV) since 2009 (Until Q1 2017) is the Nissan Leaf (186,000 sold) followed by the Tesla model S (79,000). The best-selling plug-in hybrid EV (PHEV)– which has both electric and conventional engine – is the Chevrolet Volt (87,000)²⁴. In Europe, Norway has achieved the highest EV market penetration, amounting to 29%, implementing a national strategy to exploit the benefits of the green and cheap electricity of the already decarbonized energy sector (99% of the total electricity generation is hydropower). Netherlands and Sweden follow with market penetrations of 6,4% and 3,4% respectively. In Denmark & Netherlands the EV sales dropped due to a change in policy support. In big markets such as UK and France EV market penetration amounted to approximately 1.5%. The global EV stock surpassed 2 million units, however, despite the rapid developments, EVs are still a minor fraction of all cars in circulation (0.2%)(end of 2016). However, globally the OEMs are differentiating their production to include EVs on the aftermath of governmental mandates, declared in major European markets and China.

EV adoption Policies, Regulations and Incentives

The early stage of EV market has shown peculiarities, which derive from the nature of the technology. EV technology, being an important structural component of the global strategy for Climate Change mitigation, it substitutes the proven ICE vehicle

²⁴ D. Fickling, (2017), "Electric Cars Reach a Tipping Point Prediction of electric vehicle take-up"

technology which has undergone many years of development and regulatory integration. It is therefore obvious that EVs cannot compete in economic terms with ICE vehicles, at least in this early stage of their development. Thus, so far EV introduction has been policy driven and is also subject to further global policy imposition until the technology, the manufacturing methods and the supporting infrastructure technology matures to form economies of scale, achieving a significant decline in the value of EV acquisition and ownership cost. A various means to promote EVs such as incentives, policies, targets, mandates and regulations have been used by many countries during this early phase of the EV market development. These include national targets, mandates and regulations, financial Incentives, policies aiming in increasing the value proposition of EVs, public Fleet procurement etc. Moreover, market experience in various European countries has shown that influence of applied policies and incentives reflect directly on the EV sales.

Targets, mandates and regulations: Targets are an important tool for the policy-making process as they move the focus from the policy selection debate towards the policy implementation and its assessment. Mandates and regulations build on the definition of regulatory targets to provide a clear signal to manufacturers and customers as they set a medium- to long-term vision for defining the evolution of vehicle characteristics. Most significant measures in this category include zero-emission vehicle (ZEV) mandates and fuel economy regulations.

Financial Incentives: The financial incentives directed at EV users and customers are essential for reducing the acquisition cost, mainly dictated by the high battery cost, and the total cost of ownership, in order for EVs to compete with ICE vehicles in the open market. The role of the financial incentives is to support the consumers and EV users financially in order to make EVs fictitiously an attractive option in the automotive market. Therefore, their goal is to initiate and reinforce a positive feedback loop, which based on sales increase will drive the production scale-ups and the technology learning to further reduce the cost of EV batteries and other components making EV ultimately a viable market option. EV incentives can take the form of (a) direct rebates, (b) tax breaks or (c) exemptions, and can be framed in (d) technology-neutral, differentiated taxation that favors low-emission vehicles according to their GHG and pollutant emission performance and penalizes vehicles with high environmental costs.

Policies aiming in increasing the value proposition of EVs: EV deployment can be supported by increasing the appeal of EVs over competing alternatives, providing advantages in terms of reduced fees, privileged access, driving facilitations. These policies focus to the support of EV ownership and use, and consequently must be

developed in a municipal level and adapted to the unique local conditions of each urban area.

Public Fleet procurement: The public authorities as well as the private sector can contribute significantly to the deployment of EVs by providing the market with demand signals, while exploiting their societal role; thus, they could act as advocates of EV promotion through their staff and customers.

Policy influence on EV deployment: As mentioned above, the deployment of EVs this early in such a premature EV market stage is policy driven. In this stage market sales are volatile and directly influenced by the annual developments of financial support policies applied in local markets. Policy strategies are also uncertain, as policy makers try to identify the transition to higher market maturity and consequently higher financial sustainability. Miscalculation in this identification might lead to local EV market crashes derived from the neutralization of vital for the market support policies and incentives. On the other hand, market experience showed that more fiscal incentives can revitalize an unresponsive market.

Moreover, the influence of applied policies and incentives reflect directly on the EV sales. Significant is the example of the EV market development in Norway, which showed a very high growth of PEV sales in 2016, with preference being the PHEVs, as a result of higher purchase rebates and tax waivers introduced for PHEVs in 2016. However, even though there were introduction of a 25% exemption of the car purchase value tax on BEVs as well as waivers on road tolls and ferry fees the market only responded with growth of 6% of BEVs' sales, most probably because of peculiarity of the terrain and the extended driving range needs of vehicle owners. In the Netherlands, the application of the differentiated CO₂ based taxation scheme, with gradual annual increase of taxation rates affected the market of PHEVs shifting the market towards BEVs. On the contrary to other markets, Sweden, while reducing the purchase rebate offered to PHEVs it has seen the sales of PHEVs growing rapidly to 86%, probably due to the large amount of PHEVs sold as company cars exploiting the still valid monthly "fringe benefit" offered for the use of plug in cars as corporate vehicles²⁵. On the other hand, Denmark has seen its EV market collapsing in 2016 after phasing out the 20% registration tax exemption for EVs. On the aftermath of the market collapse, the Danish authorities reinstated the exemption for the next 5000 EVs or the end of 2018 along with a battery capacity-based purchase car rebate on EVs in hope of the EV market's recovery.

²⁵ P. Kasche, (2017), "Personal communications of the authors on the status and projections for the deployment of electric vehicles in the Sweden, March and April 2017."

Table 4 BEV and PHEV incentives developments in a selection of countries 2016
(Source: IEA)

Country	2015 vs. 2016 policy developments		2015 vs. 2016 sales growth		2016 sales	
	BEV	PHEV	BEV	PHEV	BEV	PHEV
China		~	75%	30%	257 000	79 000
United States		~	22%	70%	86 731	72 885
Norway	~	↗	6%	164%	29 520	20 660
United Kingdom		~	4%	42%	10 509	27 403
France		~	26%	36%	21 758	7 749
Japan		~	48%	-34%	15 461	9 390
Germany		~	-6%	20%	11 322	13 290
Netherlands	~	↘	47%	-50%	3 737	20 740
Sweden	~	↘	0%	86%	2 951	10 464
Canada		~	19%	147%	5 220	6 360
Denmark		↘	-71%	-49%	1 218	182
Korea		~	75%	-40%	5 099	164

Battery Cost and Performance

The rapidly decreasing cost of batteries, which is the most cost intensive EV component, would be the main driver for dropping the price of EVs in the near future. Therefore, the cost of EV batteries fell by 73% between 2010 and 2016 (BNEF, 2017). The technological development comprising the increasing volumetric energy densities of EV batteries and battery chemistry improvement, which combined with the rapidly decreasing manufacturing cost caused by the achievement of economies of scale in manufacturing, and aggressive pricing strategies by large scale producers, drives the battery cost reduction. Research and development had lead into the formation of a competitive EV battery market, in which various battery technologies are present or under development, with the most utilized and expected technologies being: Conventional lithium-ion, Advanced Lithium-Ion, Intermetallic anode (eg. Silicon alloy-composite), Beyond lithium-ion (lithium metal, including lithium Sulphur and lithium air).The five largest battery manufacturers control 64% of Lithium-ion battery capacity production for EVs. Specifically, Panasonic supplies batteries to at least 18 models, LG Chem to 12 and Samsung to 6 (Nov. 2017).

A battery technology assessment by the US Department of Energy (US DoE) shows the rapid decrease in battery cost from 2009 till 2016. Moreover, the US DoE's estimation of the current (2016) battery cost, which ranges from 250 – 270 USD/kWh, and can be interpreted as projections for the high-volume production of technologies currently being researched and is significantly higher, than the cost announced by GM and Tesla (180-200 USD/kWh) for conventional lithium-ion technologies. The current reference EV battery technology is advanced lithium-ion technology (with silicon alloy composite anode), which is currently (2017) deemed to have a greater cost but also a larger potential for cost reductions compared to

conventional lithium-ion technologies. According to US DoE, increasing production of a 100 kWh capacity BEV battery pack from 25,000 to 100,000 units allows a reduction in production costs of 13% per kWh. Moreover, according to recent research, battery pack production comprising of over 200,000 units/year are estimated to cost 200USD/kWh or less, which is 33% less than the 300 USD/kWh estimated for production volumes ranging between 10,000 and 30,000 units in 2015²⁶. In addition, increasing the battery pack size from 60 kWh to 100 kWh would consequently lead to a manufacturing cost reduction of 17% per kWh of EV battery storage capacity. The projected battery costs for 2020 (Tesla), 2022 (GM), are optimistically below the forecast made by US DoE for the average battery cost.

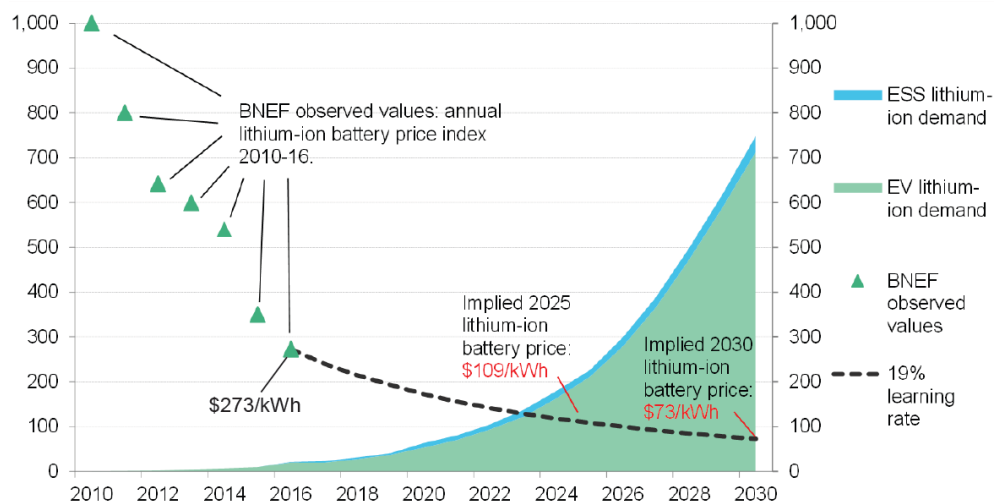

Figure 5 Lithium-ion battery historical and forecasted prices²⁷ (source: BNEF 2017)

In recent study Bloomberg New Energy Finance (BNEF) estimated that the EV battery cost will decrease below \$100/kWh by mid-late 2020s, reaching an average price of \$73/kWh in 2030. The same study predicts that economies of scale of an average up to date battery production unit of 3GWh/year production capacity potential, will have an effect in battery price reduction of 2.5% while technological advancement will lead to a battery pack capacity increase of 5% per annum, achieving a twentyfold production of 60GWh/year by 2030. The battery price reduction development will lead to a steady decline of EV cost, with expected acquisition cost equivalence with ICE vehicles expected to be achieved in 2025. In addition, the overall progress of EV battery development is expected to drop the battery cost to prices below a quarter of their current value (2030), leading the EV cost to an average price of 65% of the 2016's value by 2030.

²⁶ P. Slowik et al. (2016), "White paper: Assessment of next-generation electric vehicle technologies"

²⁷ Prices are for cells plus packs and are an average of BEV and PHEVs. Cell-only prices will be lower. Historical values are nominal; forecast values are in real 2015 US dollars

A new analysis by MIT researchers indicates that without proper planning there would be short-term shortages of some metals required for the rapidly increasing lithium-ion EV battery manufacturing²⁸. This specific study, by Olivetti et al, The specific study, by Olivetti et al, showed that while nickel and manganese, being materials used much more widely in other industries, are not affected even if the battery production ramps up in very high levels in the next decade, a short term scarcity could appear in Cobalt and Lithium supply.

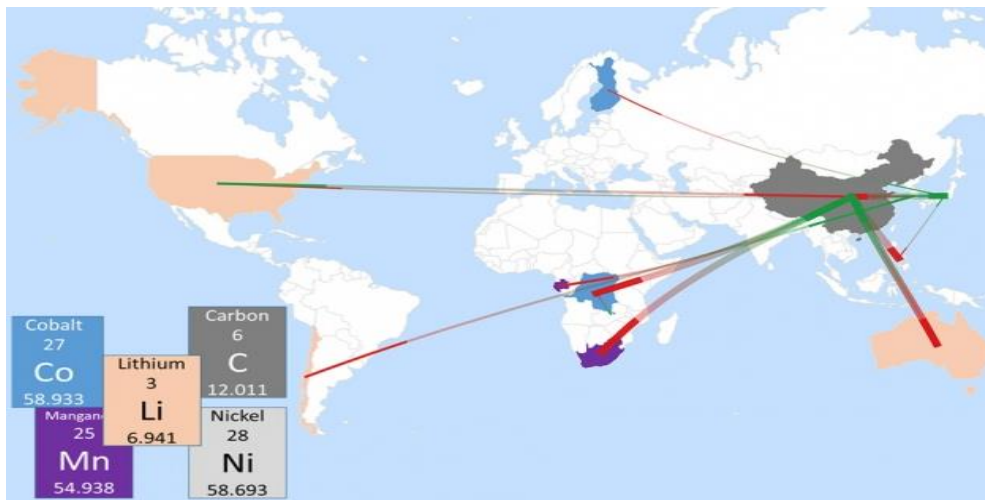

Figure 6 trade flows of key ingredients for battery production (source: MIT Department of Materials and Engineering)

Moreover, according to BNEF the global reserves of lithium are not close to depletion even with the consideration of the great growth of the EV market, which is expected to increase more than thirtyfold by 2030 dragging upwards the battery manufacturing and the lithium demand.

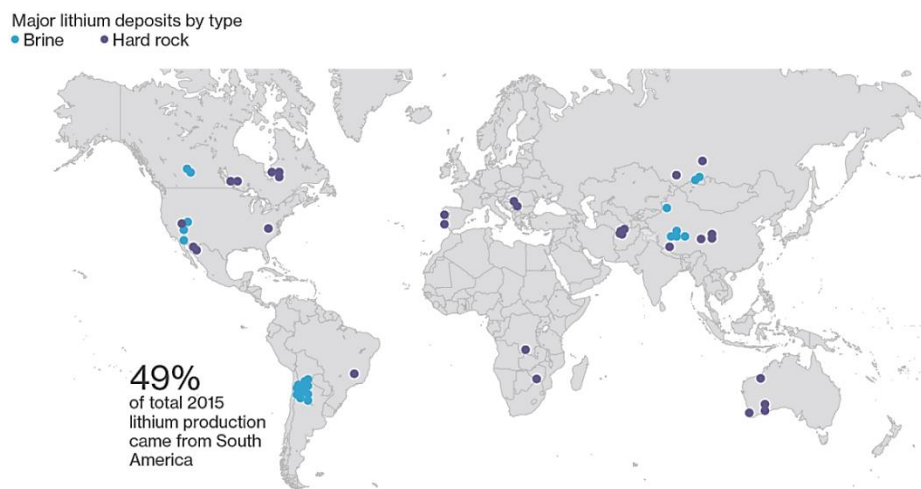

Figure 7 Major Lithium deposits by type (sources: Deutsche Bank, USGS, BNEF)

²⁸ D. L. Chandler, (2017), "Will metal supplies limit battery expansion? Rise of electric vehicles and grid storage may cause bottlenecks, but no showstoppers, analysis suggests."

It's characteristic that in the next decade, taking into account the great increase of the EV market, it's expected that less than 1% of the known lithium reserves will be extracted. Deutsche Bank estimates that even if the market triples there are 185 years' worth of known reserves in the ground. However, in 2015 fear and speculation of a probable scarcity almost tripled the prices of the battery grade lithium to more than \$20,000 a ton, in just 10 months. This increase was reflected on an instant rise in the price of EVs, propelling the EV market in competing with other markets for lithium resources²⁹.

The lithium supply is either originated from hard rock mining or processing of brines. The lithium production from brine, which accounts for half of the global production of lithium, can ramp up much more rapidly, within a short period of six to eight months, in comparison to the fairly slow process of establishing new underground lithium mines. Mining companies have announced the addition of 20 lithium production sites to the 16 currently operating (2017b), the first of which is scheduled to open in 2019, but the concern remains that they won't be finished in time to satisfy rising demand. Study by Deutsche Bank predicts that beyond 2018 the lithium industry will be directed towards implementing projects of lithium extraction from brine, which account to 76% of the global reserves, and despite being more capital intensive, exploiting their inherently lower costs and greater economy of scale will offer lithium abundance and push the marginal cost of lithium down in the long term³⁰. In agreement to these predictions, Olivetti states, that even though there might be disruptions in the supply of lithium, it's improbable that these will majorly disrupt EV battery production.

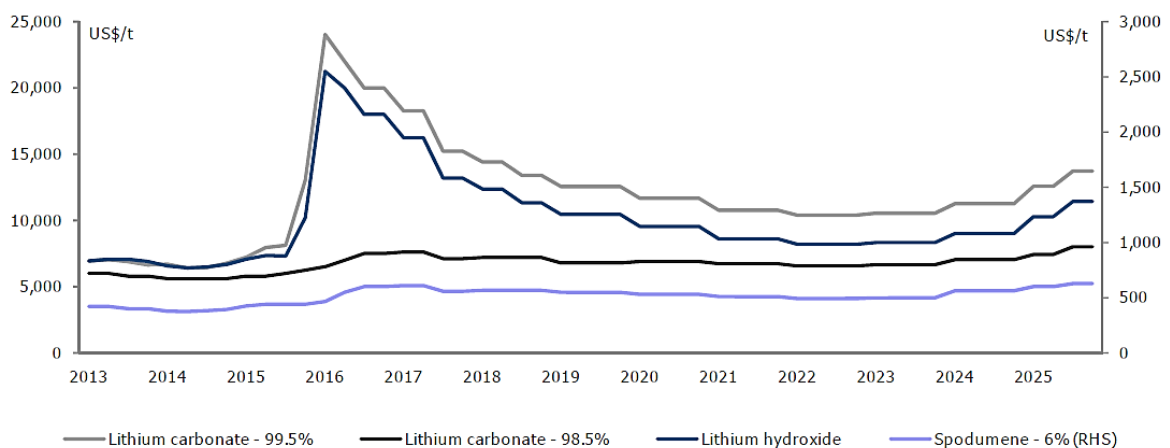

Figure 8 Price forecasts for 99.5% & 98.5% lithium carbonate, lithium hydroxide and 6% spodumene concentrate (sources: Deutsche Bank & Asian Metal company data)

²⁹ J. Shankleman, et al. (2017), "We're Going to Need More Lithium-There's plenty in the ground to meet the needs of an electric car future, but not enough mines."

³⁰ Lithium Today, "Lithium prices retrieved in 25.02.2018"

Cobalt supply is a more complicated case since one of its main sources is the Democratic Republic of Congo, which has a history of violent conflict and corruption. Cobalt is typically a byproduct of other mining activity, typically nickel and copper extraction. The main problem that disrupts the cobalt supply is focused on the inability to initiate new mining operations, since higher prices induced by scarcity won't stimulate new supply in the way they would in other commodity markets. Even so, the market of cobalt has doubled from the end of 2016 to the end of 2017 reaching a market value of \$8 billion, but its value is expected to be stabilized or even drop by 5.3% (to \$68,200/ton from \$72,000/ton) in 2018, as projected by BMO Capital Markets, while Glencore Plc and Eurasian Resources Group ramp up major new cobalt projects in 2018 and 2019³¹. The, beyond expectation, expansion at Glencore's Katanga project in Democratic Republic of Congo, seems to delay the onset of a cobalt shortage that many analysts see emerging as the use of EVs is beginning to spike toward the end of 2010s.

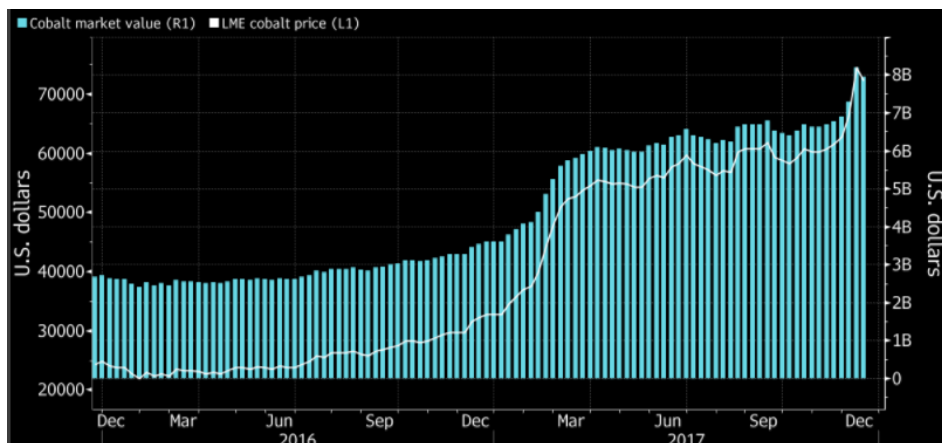

Figure 9 value of global cobalt market and cobalt price development in 2016 -2017 (sources: LME; 2016 output data from Darton Commodities retrieved by Bloomberg)

The cobalt extraction industry is expected to grow further with the integration of three major planned projects but also numerous potential ones. The recent increase in cobalt price has also sprouted an increase of cobalt recycling industry's volume, which is expected to reach 22,500 tons in 2025 from 8,700 tons in 2017 according to Creation Inn, a London-based research firm focused on energy storage and recycling. According to Colin Hamilton, managing director for commodities research of BMO Capital Markets, the automakers are expected to push the battery industry for cobalt substitution, given the increased cobalt prices and its projected scarcity. This can be confirmed by the projected cobalt mining operations, which are not expected to follow the EV battery market growth beyond 2025, when to counteract on potential cobalt scarcity the battery industry will be directed towards less cobalt dependent cathode materials for lithium-ion batteries.

³¹ M. Burton, (2017), "How Batteries Sparked a Cobalt Frenzy and What Could Happen Next"

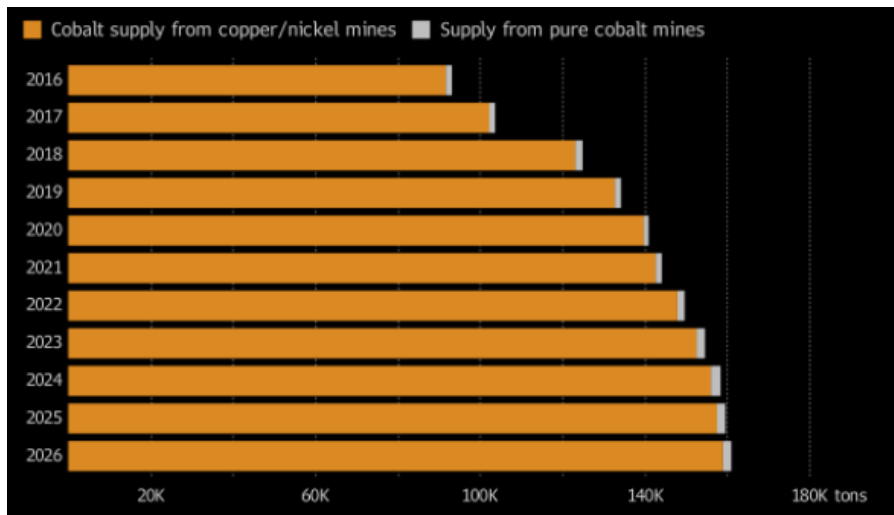

Figure 10 Projections of Cobalt supply from copper nickel mines (sources: CRU, Bloomberg)

A study conducted by BNEF shows the impact of the price fluctuation of various metals in lithium-ion battery price. Important findings of this study are that analyzing a typical NMC (111) lithium-ion battery, used amongst others by BMW and Chevrolet, showed that cobalt has the biggest price leverage of total battery pack cost increase of 4.3% per doubling of its price, which occurs due to its already high price of \$75/kg. This leverage of the cobalt in battery packs is also more impactful because of the volatility of cobalt’s price caused by short term bottlenecks in supply , which as mentioned above are caused by the inability of the mining industry to constantly adapt to the continuously increasing demand.

Even though the price of lithium has skyrocketed reaching approximately \$22/kg (02.2018) it is still relatively low to significantly affect the battery pack price since indicatively the NMC(111) battery pack contains only 12% Lithium compared to the 30% of the expensive cobalt. Even if the price of lithium soars up to 300%, the reference battery pack (NMC(111)) costs would rise only by about 2%.

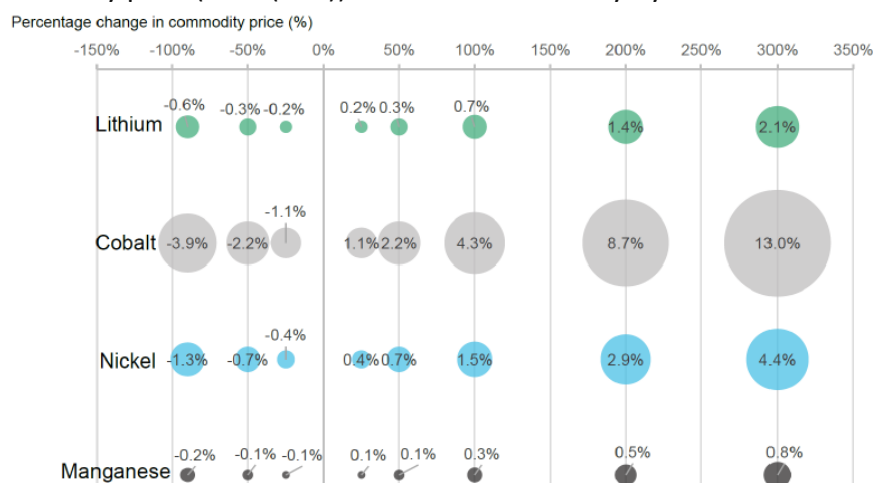

Figure 11 Impact of raw material price fluctuations on NMC battery pack costs (%) (source: BNEF 2017) *Note: NMC chemistry modelled here is NMC (111); NMC battery pack cost is \$223/kWh)

Also nickel's price shows a significant leverage for the price of NMC(111) battery pack reaching 1,5% per 100% increase. However, it seems that nickel's price is unaffected by the rapidly expanding EV battery market with its main volume still being used in the steel industry.

The uncertainty in the price of lithium-ion battery metals is significant, mainly because of prior historical price manipulations. A significant reference case was the severe nickel market price manipulation in 2007, which skyrocketed the nickel price over \$52,000/ton from \$12,000³² in a period of a year, induced by its scarcity resulting from its mass use in the newly introduced production of the metallic alloy NPI (nickel pig iron)^{33 34}. This raises concerns of whether li-ion battery metals' prices will ever undergo such manipulation, how long will this crisis be and how will the battery industry, and by extension the EV industry, be affected by it. The market overcame the Nickel crisis by ramping up its production, which gradually adapted to the demand of NPI production, securing abundance and market price stabilization while the effect of the economic crisis also contributed in the drop of the price to values prior to 2007.

To overcome such bottlenecks, battery producers and global automakers are trying to stock up raw materials for their foreseeable needs taking into account the scaling up of production. As such, Tesla is currently in talks with Chile's SQM to invest in lithium. SQM's lithium production from brine is one of the cheapest globally and thus Tesla is examining the viability of the investment in processing technology to produce the battery grade Lithium hydroxide, used by its car batteries, directly from the ground. Furthermore Toyota agreed to buy a 15% stake in Orocobe which produces lithium in Argentina³⁵. Cobalt is the most sensitive metal in terms of price volatility due to its scarcity and thus it is a potential target for market manipulation. This fact leads EV manufacturers and battery producers to invest in battery technologies with low cobalt dependency. Such an example is Tesla, which produces and utilizes NCA Lithium-ion batteries containing 14% Cobalt in comparison to NMC (111), (433), (532), (622) Lithium-ion batteries, which contain 30%, 27%, 18% and 18% respectively³⁶. Moreover, the battery industry has seen a transformation since 2014 with the introduction of larger facilities with producing capacity on a multi gigawatt scale, being the dominant trend in today's industry (2017), with 26 battery cell plants that are either in production and due to expand capacity or new operations due to be in production by 2021 with a combined operational and planned

³² *InfoMine – InvestmentMine*, "Historical Nickel Prices and Price Chart" [Accessed on Jan 2018]

³³ A. Evans-Pritchard, (2007), "Nickel price 'loses touch with industrial reality'"

³⁴ *International Nickel Study Group (INSG)*

³⁵ H. Sanderson, (2018), "Tesla in talks with Chile's SQM over lithium investment"

³⁶ S. Gandon, (2017), "No cobalt, no Tesla?", *Tech Crunch*

capacity of 344.5GWh³⁷. The industry is ramping up production rapidly to satisfy the future battery demand resulting to an increase of 11% (10GWh) of the total installed production capacity during 2017 and an increase 19% of the total announced planned production capacity for 2021 (from 289 GWh to 344.5GWh).

Also the need to localize production to support the local EV industry is also one of the highlighted trends in the battery industry. China is the dominant force in the industry with 49% of the planned capacity totaling 169 GWh followed by Europe with 23% consisting of 78.5 GWh, while the US is 3rd with 53GWh corresponding to 15% of the total capacity. It is notable that Tesla has announced that beyond 2021 its battery producing plant, known as “Gigafactory” should be able to propel the production to 150GWh/year to meet the demand caused by the mass market scale of production of its EV, Model 3, feat which deemed significant, as such capacity would represent a significant portion of the global battery production.

A forecast from Benchmark Mineral Intelligence foresees that new plant announcements would be likely made during 2018. Tesla is expected to announce more details on its planned production unit in Shanghai, China, which is expected to be a vertically integrated battery facility, where it is possible to be the ground for collaboration and joint ventures with other auto manufacturers to build foundations for EV industry development. Moreover, many large battery production units are announced expecting to triple the size of the industry by 2021, but these announcements in a rapidly growing market create volatility in market predictions as the implementation of all the announced projects is far from settled. This fact is expected to create uncertainty amongst the auto manufacturers, posing a major challenge and risk for the EV industry in the next 5 years, given the fact that the total announced battery production capacity is deemed necessary to satisfy the production ambition of the autoproducers.

B. Global Trends and the Future of EV Market

Increased Diversity of Electric Vehicle stock: During 2017 Manufacturers have introduced in the market various battery electric vehicles (BEVs) and plug-in electric vehicles (PHEVs) in most vehicle classes. Over 50 different BEV models are available worldwide³⁸, while 36 new models are expected to enter the market during 2018³⁹. Moreover, a large variety of PHEVs are available in the market providing a longer driving range alternative. This variety effect can also be observed in China, where the

³⁷ Benchmark Mineral Intelligence, (2017), “Rise of the lithium-ion battery Megafactories: What does 2018 Hold”

³⁸ *European Alternative Fuels Observatory (EAFO)*, “Database: Fuels – Vehicles: BEVs”

³⁹ evrater, The “Electric Vehicle List - An up-to-date list of current and future full-electric cars.”, [Accessed Jan 2018]

OEMs achieved a 43% of EV production worldwide (2016), introducing 25 new EV models in the market. Survey study by McKinsey & Company in 2017, revealed that Chinese consumers can choose from 75 EV models, more than any other country. The diversification of the EV stock also highlights the differentiated mobility services each vehicle can provide. One of the dominant product differentiations, which emerge in the EV market, points to either increased driving range or to energy efficiency to be the key characteristics in market options for BEVs, while the market of PHEVs is, in addition, oriented towards fuel efficiency as well.

Survey by BNEF, based on automakers' stated electrification targets, showed that we can expect more than 220 EV models to be available in the market as soon as 2021. This fact in combination with the rapid development in EV battery technology would lead to further diversification to the global EV stock due to rapid aging of technology.

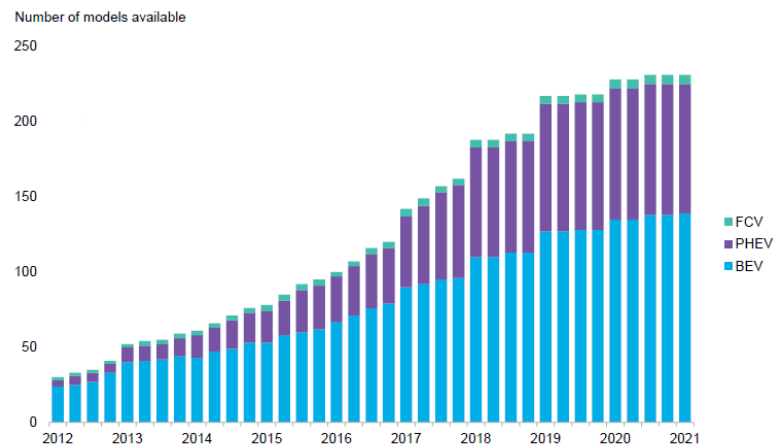

Figure 12 EV model availability (source: BNEF 2017)

A shift from buying cars to buying mobility: The automotive future might be far different than its recent past. Disruptive technologies, government policies and new business models converge to the popularization of mobility as a service (MaaS) as opposing to car ownership, such as smart ride hailing and the much anticipated autonomous self-driving vehicles. A study by IHS Mark is forecasting the automotive future of 2040, outlining bizarre changes on the transportation sector. Moreover, it is expected that more travel by car will occur with fewer cars. The MaaS industry is expected to purchase more than 10 million cars in the key markets of the future (2040) compared to just 300,000 in 2017. MaaS companies will be key adopters of EVs and driverless cars with a trend to buy their own fleet as opposed to drivers providing their own cars. Already, various schemes of car/bike sharing had already flourished and penetrated the market of various European urban areas.

The new mobility business models have promoted the success of various stakeholders in the mobility market. The most successful mobility business models are: (a) Peer to peer ride sharing, which is well represented by “Blabla car” and “Scoop”, (b) Peer to peer car sharing, in which the major players are “Easy Car club”

and “Flight Car”, (c) On-demand ride-hailing, in which the most success is realized by “UBER” and “Di Di Chuxing” (China) and (d) Operator car sharing, in which major players are “Zipcar”, “CAR2GO” and “KANDI”. The most successful MaaS platform is Uber, a car hailing on demand platform, which has spread to 71 countries since 2009.

However, the influence of such models in global markets bare many risks since they pose distraction for local economies and thus can be marginalized in various cases, baring the heavy cost of adaptation failure. In contrast to such business models, some sharing economy transport companies operate in one national market for many years having much more adaptation and financial success than those ones that become highly internationalized. For example, local companies such as the Chinese “Didi Chuxing”, founded in 2012 and “Lyft”, founded in 2012 in San Francisco, California, have raised \$4,4 and \$2 billion in capital respectively⁴⁰. There are also various initiatives in the automotive industry promoting MaaS business models. The paradigm of Daimler’s business activity as a mobility provider could prove market changing, considering the resources and knowhow that the automotive giant can provide. As a result its Daimler mobility services are deemed a successful business operation counting 15 million customers in more than 100 cities across Europe, North America and China. Specifically its subsidiaries “car2go”, (global market leader in free-floating sharing), “mytaxi”, (European market leader in car hailing on demand services) and “moovel” more than doubled in the first half of 2017, while since late 2016 Daimler has also been providing private car sharing through “Croove”⁴¹.

Future of EV market: Various economic studies have attempted to predict the future of electric vehicles. BNEF in one of its studies (2016) predicts that the rapid development and cost reduction in battery technology during the 2020s will make EVs a more economic option than gasoline or diesel cars in most countries. Moreover, the study forecasts 60 million new EV sales by 2040 corresponding to 54% of new light duty vehicle sales.

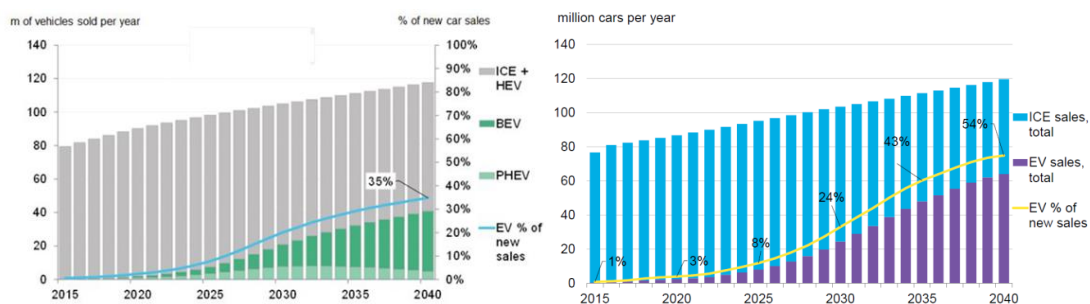

Figure 13 BNEF's predictions (a:2016, b:2017) for the new EV sales till 2040 (source: BNEF)

⁴⁰ A. Kosintceva, (2016), “Business models of sharing economy companies: Exploring features responsible for sharing economy companies”

⁴¹ Daimler, (2018), “Plans for more than ten different all-electric vehicles by 2022: All systems are go”

Such a development would displace the use of 19 million barrels of crude oil per day on the transport sector, substituting it with 10.82 TWh of electricity per day which would account to a consumption of 3950 TWh annually, equivalent to 16% of the electricity consumption of 2016. The study is based on the crude oil price prediction, assuming a recovery to \$50 and trending up to \$70 per barrel or higher by 2040. An alternative scenario considering the oil price falling to \$20 would lead to a delay to mass adoption of EVs to the early 2030s.

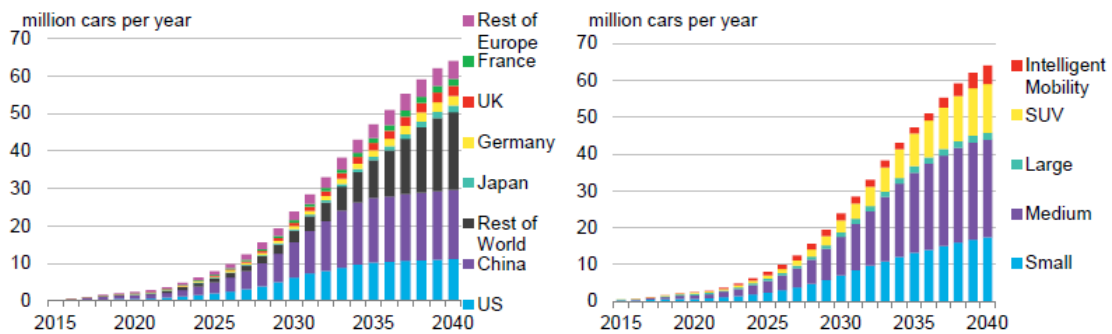

Figure 14: Forecast of Annual new EV registrations per region Figure 15 Annual forecast of new EV registrations by class

According to this study the major characteristics dictating the optimism of the scenario is the rapid decrease of battery prices in period 2016-2017 and the commitments made by the automakers in the same period. Furthermore the study predicts a global fleet of 7% and 33% EVs in 2030 and 2040 respectively, pinpointing a change in the rate of EV introduction, which is translated in an inflection point in the EV deployment curve. Such development is based on a prediction that EVs will become more economic on an unsubsidized total cost of ownership basis across mass-market vehicle classes. Other studies that focus in the EU, based on the recent and expected developments in the EV industry, are expecting a 10-20% total market share of EVs by 2025. The share of EVs in new vehicle sales could approach 100% as in major European markets, including Norway, the Netherlands, and Germany, the governments and local autoproducers are collaborating towards the implementation of phasing out gasoline and diesel cars within 2025-2030⁴².

Mandates set by governments could quickly incentivize the industry leading to economies of scale which could drag production volume to many hundreds of thousands of EVs per year in the time frame of 2020-2023. As a result, leading companies' battery pack costs would decrease to \$150- \$175 per kilowatt-hour in the same period of time. However, predictions of various organizations for the performance of EV industry are contradicting to each other, mainly because of the high complexity which such estimations require, with many parameters in place influencing the future development of EV industry.

⁴² Bellona Europa, (2017), "EU contemplates introduction of minimum quotas for the sales of electric vehicles"

EV forecasts at-a-glance

EV fleet size

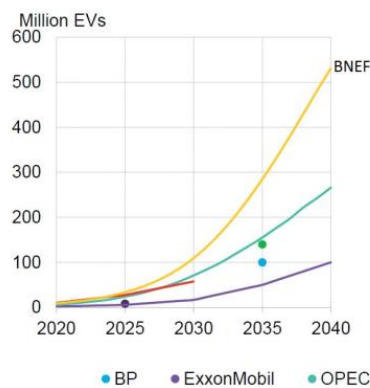

EV share of new sales

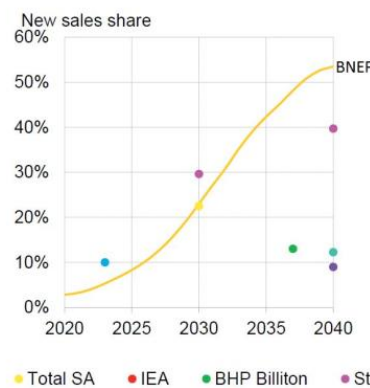

EV fleet share

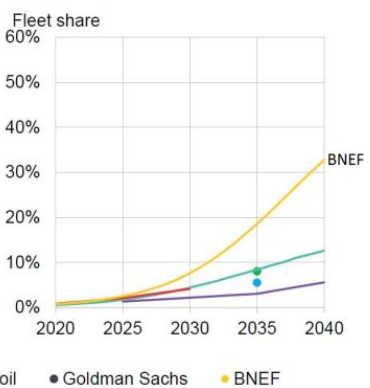

Source: Bloomberg New Energy Finance, organization websites.

Figure 16 EV market forecasts by various organizations (source: BNEF)

The EV market's performance will be heavily influenced as mentioned above by the oil industry's rally towards an imminent peak demand, which Royal Dutch Shell predicting it could be one decade away. This prospect will collapse the oil prices as the market shifts away from the oil products⁴³, halting temporarily the rally of EV market expansion. The price of the oil low and the coinciding phase of the EV market are going to determine the duration of the bottleneck of the EV market expansion. IHS Markit, taking into account the development of alternative fuels, predicts that cars that solely powered by petrol and diesel will have fallen below 50% by the year 2031, while EVs will account to more than 30% of the cars sold in major markets by the year 2040. Moreover the market overtake of EVs is expected by BNEF to happen in 2038 while acquisition cost will reach parity with gasoline and diesel ICE vehicles will be achieved by 2025⁴⁴.

C. Greece's EV Market

Greece is an energy depended country, with a net import (import-export) of 18.8 Mtoe in 2015, of which 80% was referred to petroleum and 14% to natural gas. The domestic energy generation in Greece amounted to 8.4 Mtoe, from which the 67% was solid fuel (mostly lignite) and 31% was RES. The electricity consumption in 2015 amounted to 4.37 Mtoe ⁴⁵ of which approximately 18% was imported. The transport sector consumed only 0.8% of the total electricity consumption, most of which came from rail transport. The market for EVs in Greece is in its infancy accounting for only 334 passenger PEVs in circulation in 2017⁴⁶, while the local fleet includes also 113 passenger tricycles, 124 electric motorbikes and 14 electric trucks (2016).

⁴³ *The Economist Leaders* – "Roadkill", issue August 12th 2017

⁴⁴ J. Shankleman, (2017), "The Electric Car Revolution Is Accelerating"

⁴⁵ *EuroStat*, "Database: Final energy consumption by product", [Accessed Dec 2017]

⁴⁶ *European Alternative Fuels Observatory (EAFO)*, "Database: Countries: Greece"

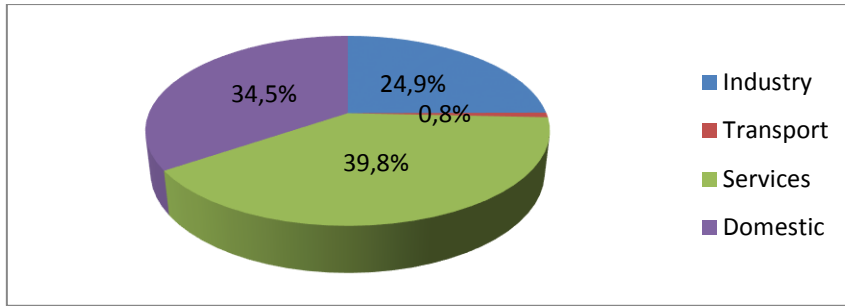

Figure 17 Share of Electricity Consumption per sector in 2015 (Source: Ministry of Environment and Energy)

In Greece the use of alternative fuels in the transport sector is limited, reaching 6,7% of total fuel consumption in 2015 excluding electricity, which amounted to 0,5% of the total energy consumption. However, 2017 has been a significant year for electric mobility in Greece as the EV market share jumped up from 0.06% to 0.19 % with the market almost tripling in volume, achieving a market growth of +243%. The most significant trend is the turn of the consumers towards PHEVs which accounted for 80.1% of the total sales (+821%). This turn is prompted by the new PHEV models that were introduced in the Greek market in 2017 mainly offered by BMW and Volkswagen (BMW 330e, BMW 225xe Active Tourer, BMW XE 40e and Volkswagen Passat GTE), providing 20 – 50 km electric driving range, which offers capability to provide cheap electric mobility within urban areas in a daily driving schedule. On the other hand, the sales of BEVs remained stable (-3%), indicating a market stagnation due to lack of fiscal incentives and supporting infrastructure.

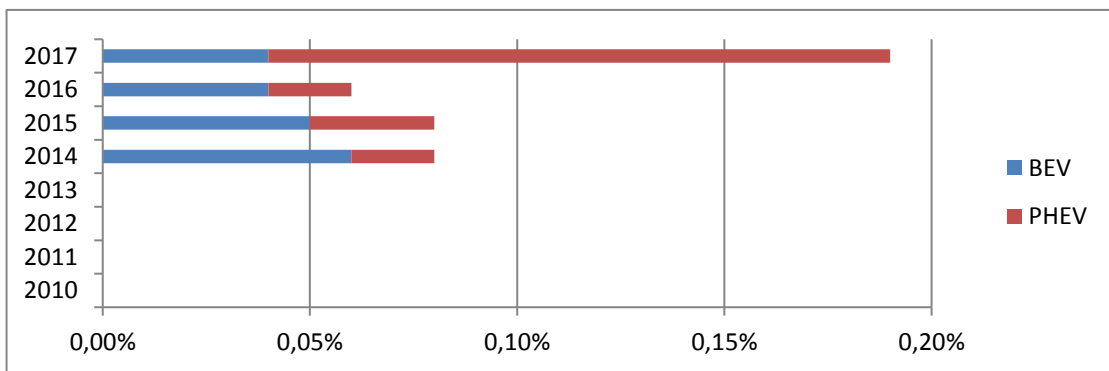

Figure 18 EV market share in Greece 2010-2017 (source: EAFO)

The EV market in Greece is majorly controlled by German OEMs with BMW being the major player with a market share of 65% and 70% on BEVs and PHEVs respectively. The commercial availability of EV models is limited in comparison to the biggest EV markets in the EU. Specifically, in the Greek market, in 2017, there were 7 BEVs and 19 PHEVs available⁴⁷.

⁴⁷ Fortisis, (2018), "Electric and hybrid electric vehicles in Greece"

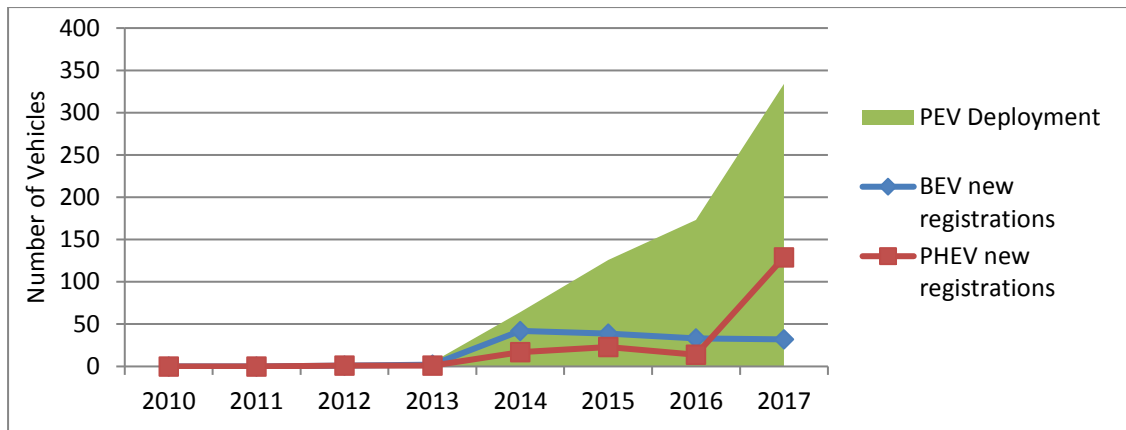

Figure 19 New registrations of plug in electric vehicles in Greece. (2010-2017) (source: EAFO)

Greece lacks the required charging infrastructure for the feasible adoption of EVs. EKO ABEE, a Hellenic Petroleum (HELPE) Group company, has first initiated an attempt to introduce EV charging infrastructure in Greece in 2011 but the attempt fell short due to the legal framework gap created by the lack of regulation of the EV charging market, which is still pending. Currently, in Greece, according to the Hellenic Institute for Electric Vehicles (HELIEV) and Plugshare, there are in total 45 public charging stations in operation, providing 64 charging ports. Moreover, 27 charging points are available through the 17 stations participating in Fortizo private charging network⁴⁸. The publicly available charging power sources, which are mostly located in the capital region of Athens, provide AC power at power levels varying from 3.5 kW to 22kW, utilizing Mennekes (type 2) and Wall Outlet (Europlug) connections, with only one charging port providing fast DC charging, (i.e. Chapter 4)

The Greek EV market is currently experiencing a vicious cycle fed by the inability of the market to provide sufficient publicly accessible charging infrastructure to halt the electric driving range anxiety of the consumers. To break this cycle, in order to initiate the market expansion, the Hellenic Electricity Distribution Network Operator (HEDNO), the local DSO, made a proposal to the Greek Regulatory Authority for Energy (RAE) for the development of Greece's first country scale charging network, composed of 1,200 to 1,500 EV charging stations connected to the national grid. RAE has to make a crucial decision assessing HEDNO's proposal as the acceptance would mean that the charging network investment costs will be passed over to the consumers via their electricity bills. This is an important disadvantage of the DSO model since it will add further socioeconomic costs to Greek consumers who have to confront a continuous economic recession. However the corresponding authorities might consider the DSO model since is the only option for the EV market initiation. Furthermore the Greek EV market's future is tightly connected with such a decision as HEDNOS proposal includes, in addition to the urban stations, 100-150 charging

⁴⁸ <https://www.fortisis.eu/fortizo-network/#the-network>

stations installed at the Greek islands and multiple fast charging stations placed in the Greek highways enabling the electro mobility for intercity transportation in the continental part of Greece. It is also expected that the installation of such a charging network will initiate an interest by investors in further expanding it, encouraging the transition of the EV charging market from the DSO to the market model. Such an event coupled by the consequent increased interest for EV acquisition by consumers, is expected to lead Greece's catch up in the global electric mobility race.

E South East Europe's EV Markets ⁴⁹

Bulgaria: In Bulgaria the EV market has been initiated slowly with many obstacles. The lack of incentives does not facilitate the adoption of EVs and thus the market performance has been low, with the consumers being reluctant in purchasing EVs. Furthermore, the circulation of EVs has exceeded the 450 vehicles in the beginning of 2018. Some of the adoption has been due to corporate initiative as "Spark", a car sharing service company, currently has deployed more than 50 EVs in the greater metropolitan area of Sofia⁵⁰, with goals of reaching the 200 vehicles deployed by the end 2018. Moreover, Electro mobility provider "eMobility International" operates a fleet of 110 rental and rideshare EVs in Bulgaria, as well as a network of charging stations ⁵¹. The company has deployed a network of "ABB Terra 53" fast charging stations, operating under the brand Eldrive, which covers the international routes from Sofia to the Greek border. It plans to extend the network to include all the country's major roads and highways by the end of Q1 2018. Furthermore, the overall charging infrastructure availability has been ramping up its development to facilitate potential EV introduction in the country. Specifically, according to EAFO, a total of 63 normal power charging points and 31 high power charging points have been deployed in the country by the end of 2017, which have been further developed by the initiative of eMobility International in the beginning of 2018.

Romania: The EV market of Romania has received a significant boost in 2017 both by declaration of Dacia for manufacturing a low cost EV⁵² and by the implementation of fiscal incentives by the Order no. 955/2016 (eurotickets) for BEVs and PHEVs. Specifically the incentives reach as much as 4450 Euros (20.000 RON) for BEVs and 1,100 (5,000 RON) for hybrids (The Official Monitor of Romania no.

⁴⁹ Due to the fact that the EV market of SE Europe is at an early stage of its development, IENE decided to approach indicatively only the markets of Bulgaria and Romania, whereas the rest of SE EV markets are subject to further ongoing observation, monitoring and research. Such observations are expected to be released in future research material of IENE.

⁵⁰ I. Mihaylov, (2017), "Latvia's Spark, Bulgaria's E-mobility launch e-car rental service in Sofia"

⁵¹ C. Morris, (2017) "Bulgarian charging network deploys ABB fast chargers"

⁵² *Energia16*, (2018), "Dacia working to build the cheapest EV in the market"

397/25.05.2016)⁵³. The deployment of PHEVs and BEVs has peaked in 2017 with the introduction of a large volume of BEVs. BEVs reached a market share of 0.22% with deployment of 232 vehicles while PHEVs reached a market penetration of 0.14% with 142 Vehicles. In the end of 2017 the deployment of PEVs had exceeded the 650 vehicles, while charging infrastructure have been steadily under development adding 14 fast charging points and 37 normal charging points publicly available for the Romanian drivers reaching a total of 19 and 95 respectively.

Moreover, German and French OEMs have been the most active brands in Romanian market. Specifically, BMW with its model BMWi3 has achieved the most sales in the BEV market segment, reaching in the span of 2014-2017 total sales of 113 vehicles amounting to 29% of the total BEV sales for the same period, while the Dacia owner, Renault, with its models ZOE and Fluence has achieved 23% of the total BEV sales (16% and 7% respectively). In regards to the PHEV market segment the most successful vehicles are again provided by the major German OEMs, BMW (X5 40e, 225xe Active tourer, i8) and Daimler (Mercedes C350e, Mercedes S500e) reaching 22% (65 vehicles) and 19% (56 vehicles) market segment penetration respectively.

4. Electric Mobility Infrastructure and Charging Stations

A. Current Charging Technology and Available Charging Infrastructure Worldwide

The components needed for a successful adoption of large scale electric mobility are identified mostly on the concepts of funding, standardization, interoperability and deployment of charging infrastructure⁵⁴. Even though the EV market is expanding rapidly, still the biggest obstacle in EV adoption is identified in the limited availability of charging infrastructure, including lack of widely utilized adequate business and financial models.

EV Charging Methods

Charging of EV batteries is majorly accomplished by three methods: Conductive charging method using plug connection, which is the most utilized method today, Inductive charging method and battery swapping technique. In this working paper the only method addressed will be conductive charging as it is the only one commercially accessible.

Conductive Charging: Conductive Charging suggests direct connection of charger and vehicle. The charging is achieved through cable connection that allows contact

⁵³ Ziare.com, (2016), "What the Government is doing to boost clean car sales - The "Rabla" program in a straight line" (in Romanian)

⁵⁴ H.T. Berge, (2016), "Europe's EV infrastructure check list"

between the power supply and the battery. It consists of a rectifier and converter with some power factor correction and it is classified as on-board and off-board charger. The on-board charger, which is embedded in the vehicle, contains the rectifier and the battery regulation system, whereas on the off-board charger these systems are placed on the charging station or the EV supply equipment (EVSE).

Charging Infrastructure, Standardization and Interoperability

Table 5 charging standards issued by the major standardization organizations (source: [17])

IEC	SAE	UL	ESO	NTCAS	JARI	JIS	ARAI
• IEC 61851-XX-1X Ed. X	• J 1772 (RIP) • J 1773	• UL2202 • UL2251	• EN 61851-X-XX • CLC/TS 50457-X:2008	• GB/T 18487.X-2001 • GB/T 20234.X-2011	• C601: 2000 • G105-1993	• TS D 0007: 2012 • JIS D 1304: 2004	• AIS-138/D1
• IEC 62982 Ed. 1.0	• J 2954 (WIP)	• UL2734 • UL2871		• QC/T 895-2011 • QC/T 841-2010	• G106:2000 • G107:2000	• JIS D 61851-23/24:2014	
• IEC 62196-X Ed. X		• UL9741			• G108:2001 • G109:2001	• JIS D 62196-3: 2014	
• IEC 61980-X Ed. X							
• IEC 62840-X Ed. X							
• IEC 62983 Ed. 1.0							

Note: X in the table symbolizes that exists multiple standards in that particular series and are denoted by series number.

The promotion of common open standards, interoperability and efficient data exchange is one of the most important steps towards facilitation of the EV adoption. Energy and electric mobility service providers should work together with the EV industry in order to create technological language in the field of EV charging that will shape the new e-mobility behavior and culture. Towards this direction the international standardization organizations have issued a series of standards that study, suggest, regulate and coordinate the EV charging technology development worldwide, as shown in table 5.

Charging modes

Important step towards the standardization and interoperability direction was made by IEC in 2010 and 2014 by publishing the IEC 62196 standard (IEC 62196-1,2 and IEC 62196-3 respectively), which along with IEC 61851 has set the foundation of today's EV charging terminology. In this document EV charging is segregated to 4 modes which are defined by the limitations of the power supply and the type of connection.

Mode 1: The EV charging Mode 1 is an uncontrolled AC charging utilizing a 1 or 3 phase circuit and socket (250V 1-phase or 480V 3-phase). The maximum charging current and power output that IEC predicts for this charging mode is 16 A and 11 kW respectively. In this type of charging the charger is built into the vehicle while it predicts no communication between the charging infrastructure and the vehicle. There is not a specific connector for the EV and the electricity supply in such a type of charging, so the EV connection to AC network is achieved by using standard power connections. In addition there are locking mechanisms of the plug and socket outlet in the vehicle, while the installation requires earth leakage and circuit breaker protection.

Mode 2: The EV charging Mode 2 is an uncontrolled slow AC charging utilizing a 1 or 3 phase circuit and socket (250V 1-phase or 480V 3-phase). The maximum charging current and power output that IEC predicts for this charging mode is 32 A and 22 kW respectively. In this type of charging the charger is built into the vehicle. There is not a specific connector for the EV and the electricity supply in such a type of charging, while the EV connection to AC network is achieved by utilizing a special cable with intermediate electronic device with pilot control function and protection. In addition there are locking mechanisms of the plug and socket outlet in the vehicle. The installation requires earth leakage and circuit breaker protection; however a protective device/pilot function is provided embedded in the cable⁵⁵.

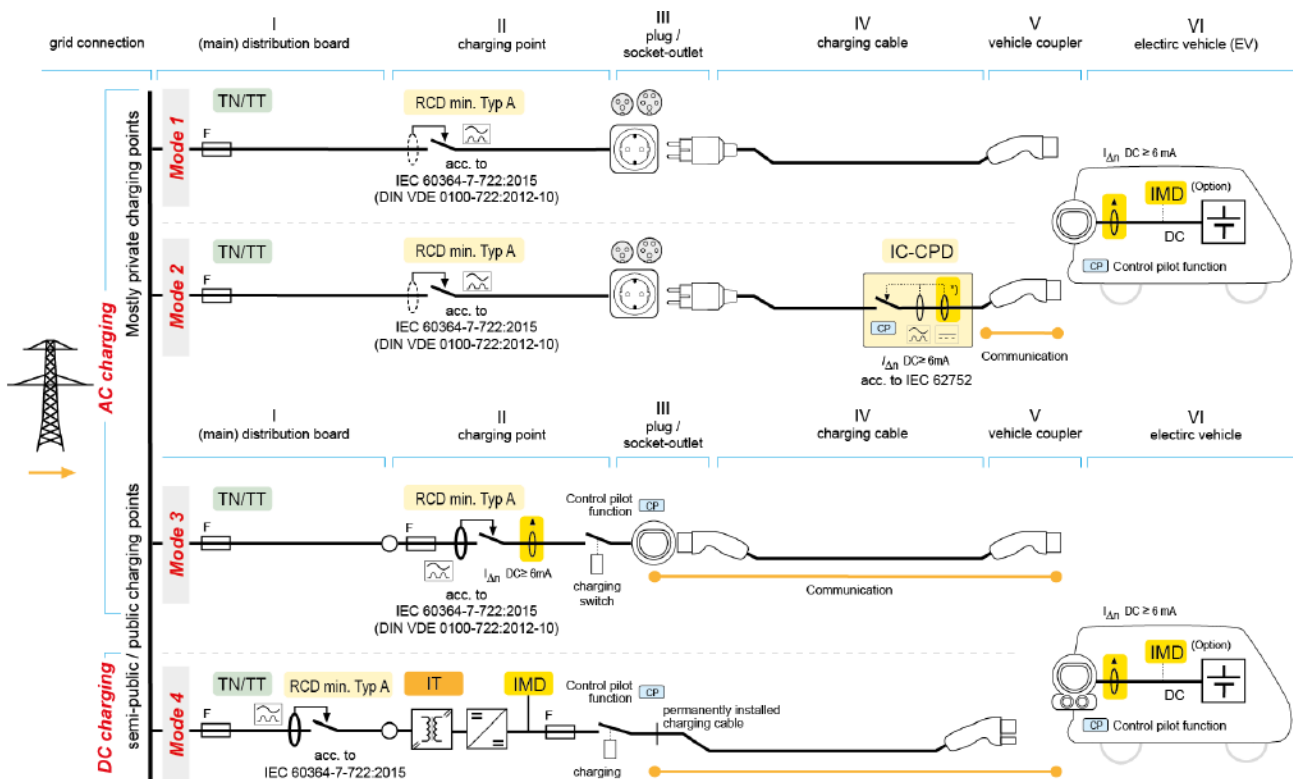

Figure 20 Charging Modes and technical characteristics of the corresponding charging infrastructure

Mode 3: The EV charging Mode 3 is a controlled, Slow or semi-quick AC charging utilizing 1 or 3 phase circuit, type-tested, supply units for electric vehicles. The maximum charging current and power output that IEC determined for this charging mode is 63 A and 43.5 kW respectively and must be in accordance with the connector used. In this type of charging the charger is built into the vehicle. There is a specific connector for EVs, whereas the EV connection with the AC power supply is done through a specific device (SAVE), while locking mechanisms are present on both sides of the plug and socket-outlet. The safety of the system is identified in the protective device/pilot function integrated into the special EV charging station. The

⁵⁵ IEC 62335 (2008)

connection between EVs and charging infrastructure allows their integration into smart grids.

Mode 4: The EV charging Mode 4 is controlled, type-tested, utilizing a DC circuit, fast DC charging stations for EVs. The maximum power supply for charging as determined by IEC for DC low voltage and DC high voltage are 38 kW and 170 kW respectively (maximum permitted current and voltage of 400A and 1000V respectively ⁵⁶), while the actual charging voltage and current is depended on the system. The charging cable is built into the charging station. In addition, the system utilizes a specific connector fixed on the external charger, while a locking mechanism of the plug and socket-outlet is present on the vehicle. The vehicle communicates with the charging station utilizing a monitoring and protective device/pilot function, integrated into the charging station.

CEN-CENELEC with the publication of IEC 62196-2 and IEC 62196-3 have issued the technical specifications of 4 type charging connectors corresponding to the standardization of regionally developed charging solutions, with Type 2 (Mennekes) being the one adopted by EU. The main DC fast charging connectors are the CHAdeMO (Japan), CCS (EU), GB/T (PRC), which share similarities but are differentiated in terms of geometry (what type of slow AC connector they accommodate), standardized power output and communication protocol.

IEC DC Charging Systems









	System A	System B	System C	
	CHAdeMO (Japan)	GB/T (PRC)	COMBO1 (US)	COMBO2 (DE)
Connector				
Vehicle Inlet				
Communication Protocol	CAN		PLC	

Figure 21 Charging systems illustration (Source: IEC)

B. Charging and Safety Issues

Charging safety features on EVSE, protect from potential electrical and fire hazards while connecting, disconnecting, and charging the vehicle. Utilization of battery management system BMS for charging control is also very important for the safe

⁵⁶ IEC 61851-1:2010

charging operation and vehicle performance. Such a system monitors and regulates the key battery operating parameters of voltage, current and temperature, controls the charging rate to provide the required constant current / constant voltage (CC/CV) charging profile and triggers the protection circuits if the battery's operating limits are exceeded, isolating the battery if needed. The Underwriters Laboratory has issued a series of standards to address the EV charging safety issues.

C. The Impact of EV Adoption on Power Generation and Distribution

The impact of EV charging on the grid is reflected on power quality, voltage drops and power losses. Battery chargers are power electronics devices, which due to their nonlinear nature can produce deleterious harmonic effects on the electric utility distribution system. According to studies the magnitude of the total harmonic distortion (THD) of the charger device's actual current (THDi) varies from 2.36% to 5.26% in the beginning of charging and could reach up to 28% at the end of charging, while other researchers claim lower THD values ranging between 1 and 2% with a power factor very close to unity. Research also pointed out that Total Demand Distortion (TDDi) limit analysis should be applied instead of the THD limitation since there is a variation of the current during charging cycles. Research also investigated the ideal topologies for residential, power level 2 (Mode 2), EV charging, which are proposed to be distribution systems with system voltage of 240/250V and power level of 8 kVA.

A significant impact of EV introduction is the voltage drop caused by system congestion induced by simultaneous EV charging. A typical charging load is between 10 to 30 kW, so a simultaneous charging of multiple vehicles in the same distribution branch might cause congestion. Under these circumstances, the voltage at customer premises might drop below acceptable and/or statutory limits. Moreover, in the case of severe overload, the distribution conductors might get damaged due to overheating. In addition, academic literature pointed at the impact of EV charging in the aging of the transformers of the power distribution system. Extended research focused on the impact of fast constant power charging has been recently commenced. Also increasing EV charging could multiply feeder losses, which would affect the power distribution system based on their relation to the load factor and load variance as illustrated in recent research works.

The growing number of EVs will eventually drive peak demand higher, which, in turn, might compromise the overall reliability of the grid. Insufficient generation and transmission, commonly referred to as blackouts and rolling brownouts, will be the impact of imbalance on the system. The grid must be capable of delivering the power necessary to charge EVs, even on the most congested days. Because of that,

the peak capability serves as the limiting factor for EV adoption under the current grid constraints. To mitigate the effects on the distribution system the distribution system operator (DSO) may upgrade the network infrastructure by installing bigger transformers and thicker conductors, but such an upgrade could be very costly, especially, if the durations of overloaded periods are short and hence will result in underutilized assets for most of the time.

D. Smart Charging Strategies

The future of electric mobility lies in efficient integration of charging needs with power demand. This future becomes a necessity, when, currently, power generation is transitioning towards high integration of Renewable Energy Sources (RES), while in the transport sector the effort for decarbonization has been focused in a turn towards electric mobility powered by “green” electricity. While RES penetration has introduced temporal and spatial uncertainty to power generation, due to the decentralized and interruptive nature of wind and solar power, the mass electrification of on-road transport has also introduced spatial and temporal uncertainty on the demand side with the introduction of Plug-in Electric Vehicle (PEV) charging. To keep the real-time balance between electricity supply and demand, while also providing PEV charging services according to the needs of consumers, in such uncertain conditions, it is imperative that a demand response from charging operations and consequently increased flexibility of PEV charging loads should be present in the power system. Such requirements have prompted the emergence of new market entities, namely PEV Aggregators, which aim at facilitating PEV smart charging services, while they participate actively in the electricity market via complex interactions with other market entities.

There are two approaches in performing demand response through PEV smart charging. The centralized approach is focusing on aggregation of charging operations, where emerging market entities (i.e. PEV Aggregators) manage temporally and spatially the charging load of a large EV fleet with advanced optimization models which are aiming at improving the quality of charging services, providing the state of charge (SOC) required by the user, while they provide ancillary services to the grid by participating in the day-ahead, intraday and balancing electricity market. The decentralized approach is focusing on individual scheduling and demand response of EV agents. Such approach is only effective when the intelligence is distributed among the power system components with the integration of smart metering and other automated processes chosen by each electric vehicle-charging infrastructure system by reflecting the condition of the local power system.

Smart Charging can also include discharging of electricity from EVs to the grid. Vehicle to Grid (V2G) technology, which is the bi-directional electrical energy flow between plug-in electric vehicles and the power grid, is used to sell demand response services by throttling the charge rate, shifting the charging time or returning electricity to the grid. Namely the benefits of V2G technology are financial benefits, which occur when efficient management of the energy stored in the vehicle can be used to avoid both peak tariffs at times of high demand and an extra strain on the power grid. The vehicles through V2G can be used as a home energy storage system helping home-owners to perform cost-effective management of power resources. V2G can also contribute in avoiding start-ups of carbon intensive units, thus contributing to the reduction of the carbon intensity of electricity. However, V2G has drawbacks in regards to the extra energy cost resulting from the extra charging, which would be required for the maintenance of the required state of charge (SOC). The extra charging also is responsible for battery depreciation roughly equivalent to 83% of the price of electricity (Greece) and capacity reduction due to battery aging. In addition maintaining the required SOC would be harder with a V2G system; thus emergency driving needs might not be covered adequately.

E. Use of EVs in an Urban Environment: The Case of Paris and other business models

Various business models have been developed either individually or in collaboration with various municipalities globally for the facilitation of EV charging and integration. Namely Autolib' in Paris, Spark in Sofia as well as various EV charging applications bringing together all parties participating in EV charging market (DSOs, charging infrastructure operators and EV users). Such applications, like "Virta" are aiming in optimizing the charging process for the benefit of all EV charging market participants.

F. EV Charging considerations for Greece

According to the Directive 2014/94/EU of the European Parliament and Commission, Greece should ensure that recharging points accessible to the public are built up with adequate coverage, in order to enable EVs to circulate at least in urban/suburban agglomerations and other densely populated areas, and, where appropriate, within networks of intercity and international transportation.

Greece, on the level of operators of publicly accessible recharging points, shall ensure that these market entities are free to purchase electricity from any local electricity supplier, subject to the supplier's agreement. Also by adapting to the EU directive 2014/94/EU Greece should adjust its legal framework to allow the operators of recharging points to provide EV recharging services to customers on a

contractual basis, including in the name and on behalf of other service providers, while all recharging points accessible to the public shall also provide for the possibility for electric vehicle users to recharge on an ad hoc basis without entering into a contract with the electricity supplier or operator concerned. Most importantly, the prices charged by the operators of publicly accessible charging points must be reasonable, easily and clearly comparable, transparent and non-discriminatory.

Estimation for the introduced load and energy requirement from the deployment of EVs in Greece has been carried out assuming uncoordinated charging of 7.4kW utilizing the widespread Mennekes (Type 2) charging modules, with a reference consumption of 0.150kWh/km, which refers to an average small EV model for urban transportation (Current technology, namely BMWi3 consumes 0.136kWh/km (2018) and Nissan Leaf (2018) consumes 0.206kWh/km). The estimation also assumes cumulative average charging losses of 20% in the points of common coupling, on EVSE infrastructure, including transformer losses

The introduction of 10,000 EVs in the system is expected to introduce annual energy demand of 17.6 GWh. The peak load of charging operations is expected to be 7.2 MW, while an increase in the annual peak demand of the interconnected system by 0.92 MW is anticipated. The Greek system is prepared to accommodate moderate loads of such proportion; however depending on the spatial distribution of the EV charging load, problems will potentially begin in volumes approximating or exceeding 100,000 vehicles. In such EV introduction in urban areas, like the capital city of Athens, maintaining about 40% of the country's passenger car fleet, peak loads resulting from EV charging could potentially reach as much as 30MW (72 MW in a country scale) and are expected to add 9.2 MW to the annual hourly peak demand of the Greek power system.

Assuming that in the time span of 2018 – 2030 (12 years) the automotive sales in the Greek market will return to volumes prior to the recession of approximately 100,000 vehicles annually and be will remain in that level, while assuming that during that span of years an average of 10% to 15% of the new sales will be EVs (both BEVs and PHEVs), it is roughly estimated that 1 to 1.2 million electric vehicles will be in circulation in Greece by 2040. Moreover, it is important to mention that as the charging load estimation performed in this study is proportional, a number of 1,000,000 electric passenger cars would result in an introduction of 1.76 TWh of annual electricity demand in the Greek power system, while a worst case scenario of 347.2 MW would be added to the annual hourly peak load demand, reaching a total of 10.2 GW. Assuming that the RES penetration will be significant for the power system to maintain its resilience under such load introduction, probably the installed power generation in Greece would have to increase significantly its capacity by 2040 to accommodate the EV charging load.

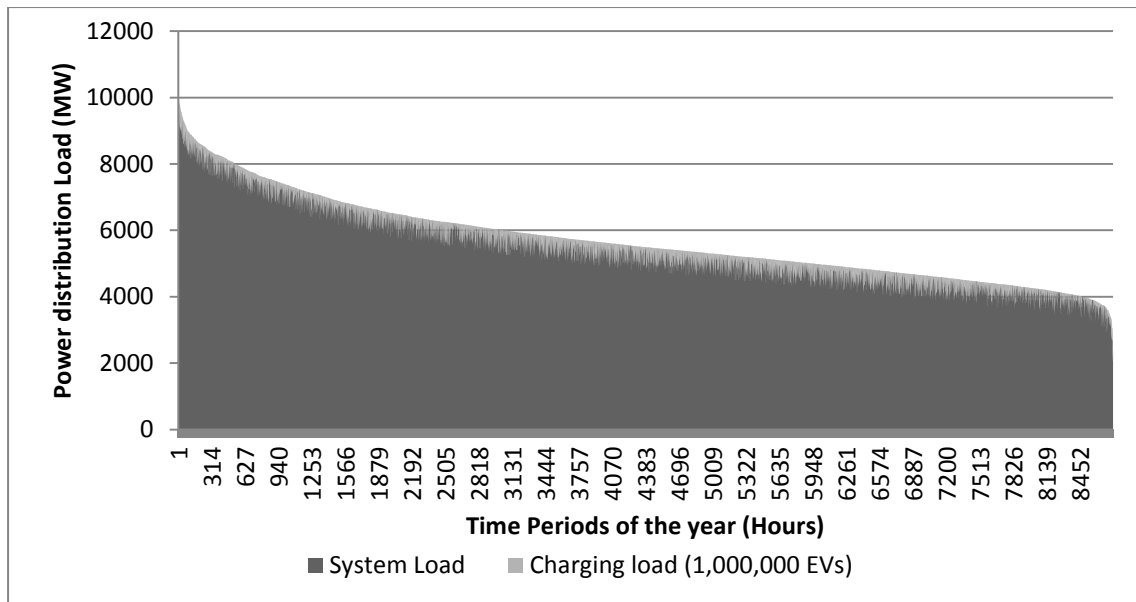

Figure 22 Load Curve of Greek Interconnected power system with the introduction of 1,000,000 EVs
 NOTE: ¹The systems refers to the load of 2017 with the addition of the charging load ²The charging load refers to urban transportation with small size EVs,(0.15kWh/km)³The mobility utilized in this study is equivalent to 9,723 km/year (2015) which is recessed and while the economy recovers it is expected to be higher

5. Cost Analysis of Production and Use of EVs

The cost of EVs in the market is an important indicator for their production costs, as OEMs are adjusting their production based on the indicated demand. Various analyses showed that, for the automakers, the adaptation phase to the new vehicle production has not yet elapsed. The already matured market of vehicle and powertrain production is expected to marginally push the EV construction cost further downwards.

Expectations for base vehicle cost reduction include body and chassis production cost reductions, which are expected to drop for battery electric cars, due to simpler design and easier manufacturing. It is also expected that electric powertrain costs for BEVs, such as motors, inverters and electronics, to drop by about 20-25% by 2030, mainly due to volume manufacturing. A study by the investment bank UBS found out that EV powertrains are \$4,600 cheaper to produce than the cost the vehicle industry endures, leaving a lot of reduction potential to be exploited in the future⁵⁷. The most expensive component of EVs is currently the battery, which is expected to contribute between 18%-23% of the price by 2030, down from around 50% at present. Parameters of battery technology market and development that will lead to such price reductions have been further analyzed in previous chapters (i.e. Chapter 2 and 3)

⁵⁷ N. Winton, (2017), "Electric Car Price Parity Expected Next Year", *Forbes*

BNEF also assumes high production EV volumes in the future for its EV price estimations, describing outputs of more than 100,000 vehicles per year. At the moment, manufacturers do not produce EVs at this scale, so unit costs for body and other parts are currently higher for EVs than ICEs with a potential for reduction of 20 - 30% in the next three to four years due to scale ups of production capacity.

Even though that Signs of market parity of ICE vehicles and EVs are evident during 2018 it is estimated that these prices do not reflect economically viable production operations. Specifically, the study by UBS also estimated that the car manufacturers lose a great amount of money due to the lack of optimal production scale ups. Specifically, General Motors is estimated to endure losses \$7,400 with every Chevrolet Bolt model sold however the development of the production processes by 2025 though, it should lead to a 5% profit margin, using the earnings before interest and tax (EBIT) measure. BNEF estimates that in the US, BEVs and ICEs in all segments will cost the same around 2026. In Europe, medium vehicles should reach price parity earlier – by 2025 – compared to small and medium cars and SUVs. In particular, small BEVs will not be price competitive until late in the decade, due to the low ICE prices in the segment.

Market analysts backed by groups like EPA, NHTSA, and by statements from US's car manufacturers, expect BEVs to reach prices 15% cheaper than the equivalent ICEs by 2030. This comparison, takes into account the assumption that costs for internal combustion engine vehicles will rise slightly in the future to comply with an increasingly stringent regulatory environment.

EV sales are correlated and should be influenced by petrol prices. As declining petrol prices help the market move towards peak oil demand, it is evident that the projected ownership cost competition between EVs and conventional ICE vehicles will turn in favor of ICE vehicles. This is due to the fact that EVs are not projected to achieve acquisition value parity with ICE vehicles until the mid-late 2020s' and at this point a rapid decline of oil prices driven by the trending electrification of the transport sector would be most probable. However, operational cost parity of ICE vehicles with EVs will not be achieved. Petrol's price decomposition for 2017 showed that in the US's market petroleum retail vendors cannot offer petrol below \$1.22 per gallon to compete with electricity prices because such a transaction would be a loss-making one⁵⁸. However, this petrol floor price could vary due to spatial and micro-economic characteristics of the market, the exploitation of which could potentially formulate a marginal price of oil for which running costs of an ICE vehicle would be competitive to the ones of an EV. In addition this competition between oil/gas prices

⁵⁸ S. Jaffe, (2016), "EV Transportation Battery Global Overview", *Cairn ERA*

with electricity could potentially push marginally the electricity prices in retail market upwards as the demand increases and more cost intensive power generation units enter the energy mix.

6. Environmental impact of EV introduction

Transport represents almost a quarter of Europe's greenhouse gas emissions and is the main cause of air pollution in cities. The transport sector has not seen the same gradual decline in emissions as other sectors; emissions only started to decrease in 2007 and still remain higher than in 1990. Within this sector, road transport is by far the biggest emitter accounting for more than 70% of all GHG emissions from transport in 2014⁵⁹. Therefore, a high potential of emissions' reduction could be realized by the adoption of electric mobility in EU, given the fact that the energy industry is reducing gradually its carbon intensity and therefore is projected to cover the energy demand of EVs with low-carbon electricity.

A. Environmental Benefits

A.(i) Avoided CO₂ emissions by the substitution of carbon intensive vehicles

Hydrocarbon fuel combustion results in CO₂ emissions. The chemical reaction of combustion of 1 liter of petrol (gasoline), 0.737 kg, of which approximately 0.63 – 0.65 kg are carbon, produces approximately 2.3 – 2.4 kg of CO₂^{60 61}. The Diesel combustion is quite similar, with the differences being identified in the ignition process, emitting 2.67 kg of CO₂ per liter. Consequently, the substitution of conventional ICE vehicles with EVs would eliminate these direct tailpipe emissions and with high penetration of RES in the energy system and better fuel efficiency could completely eliminate the carbon footprint of energy use of the on-road transport sector. Even though steps towards on-road transport decarbonization have been promoted as early as 2000 by ICCT, proposing policies aiming in reducing global oil-equivalent consumption for road transport by 9.7 million barrels per day (Mboe/day) and GHG emissions by 1.9 metric gigatons of CO₂ equivalent (GtCO₂e) in 2030⁶², only lately more radical measures have been addressed. Namely EU has set Emission targets for its vehicle fleet for 2021. The targets are set to be 95 g/km for passenger cars. Based on these targets, European autoproducers are rearranging

⁵⁹ European Commission: Energy, Climate change, Environment, (2016), "Climate Action: A European Strategy for low-emission mobility"

⁶⁰ Ministry of Natural Resources Canada, (2014), "Learn the facts: Fuel consumption and CO₂"

⁶¹ U.S. Environmental Protection Agency (EPA), (2011), "Greenhouse Gas Emissions from a Typical Passenger Vehicle"

⁶² C. Façanha, et al. ICCT, (2012), "Global Transportation Energy and Climate Roadmap: The impact of transportation policies and their potential to reduce oil consumption and greenhouse gas emissions",

their production providing vehicles with average emissions that comply with the demands of the EU commission.

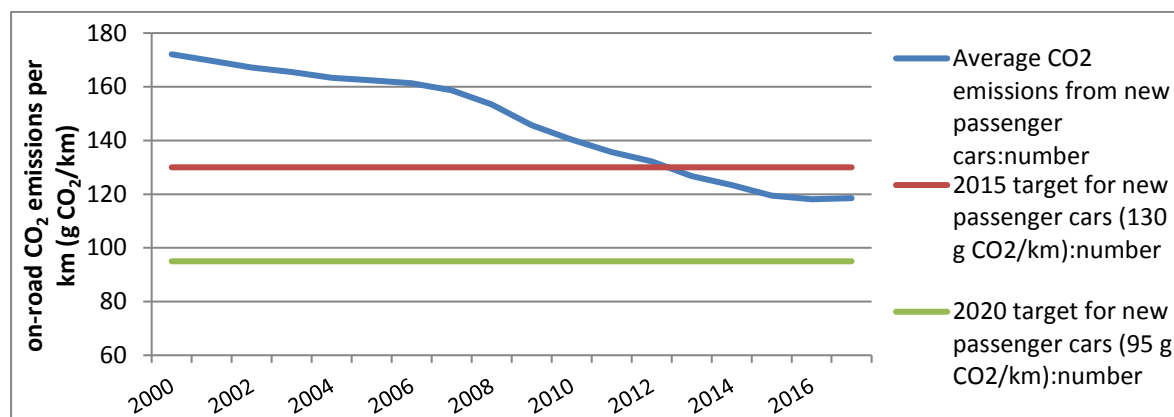

Figure 23 Figure Development of average emissions of newly registered passenger cars in EU (25)

Even though major polluters, medium and heavy duty vehicles haven't been under emissions' restriction. The CO₂ standards which are aiming to be implemented in 2025 and 2030 are currently under debate between the European Automobile Manufacturers' Association (ACEA) and European Commission. The two step approach (2025, 2030) is welcomed by the Association, while the validation at a later point of the emission goals of 2030 is a positive measure that allows the inclusion of the latest fuel efficiency technologies in the final 2030 emissions' goal. However, the proposal's aims at CO₂ emission reductions of 15% and 30% from the average CO₂ emissions of 2019 for 2025 and 2030 respectively, which has risen strong reactions from the automotive industry, deeming them far too aggressive and without consideration of the nature of the truck market^{63 64}.

On-road Transport Electrification and avoided CO₂ emissions in Greece

The transport sector in Greece is the second-largest emitting sector, accounting for 25.8% of the total energy-related CO₂ emissions in 2015. Emissions from the transport sector decreased from 22.9 MtCO₂ in 2007 to 16.7 MtCO₂ in 2015. This occurs mainly due to the shrinking of private transportation activities of the Greek population. Specifically, the average distance travelled by a passenger car per year dropped radically during the years of recession from 69,380 km/year in 2009 to 9,723 km/year in 2015⁶⁵. The passenger car fleet of Greece is one of the oldest in Europe, according to ACEA, numbering more than 3.5 million cars which are more

⁶³ European Automobile Manufacturers' Association (ACEA), (2018), "Truck industry reacts to EU proposal for first-ever CO₂ standards",

⁶⁴ European Automobile Manufacturers' Association (ACEA), (2018), "First-ever CO₂ standards for trucks must reflect market diversity, EU truck industry says"

⁶⁵ European Commission, P. Boulter et al., (2011), project "TEDDIE"

than 10 years in circulation⁶⁶. The average age of Greece’s passenger cars was 13.5 years, in 2015, while light commercial vehicles and medium - heavy duty vehicles (including buses) accounted for an average of 16.8 and 18.7 years in circulation respectively. Due to stagnation of the local motor vehicle market as a result of the economic crisis, Greek consumers tend to stick to their vehicles for a longer period of time, so in a span of 2 years (2017) the average age of Greece’s passenger car fleet is estimated to have risen significantly to 14.7 years.

In Greece, the number of light duty passenger vehicles registered, which meet the emissions target of 95g CO₂/km for 2021, has been 71,260 in the period 2010-2016, accounting for the total 12.3% of the total cars registered in the same period. While the percentage of vehicles sold that are compliant with the emissions targets keep increasing steadily. Moreover, the share of emission target compliant vehicles accounted for the 29.7% of the total sales in 2016, which is significantly higher from the 23.8% and the 18% which accounted for in 2015 and 2014 respectively, generating an incremental trend in adoption of vehicles with low carbon intensity in the country.

Given the fact that the motor vehicle market in Greece is expected to bounce back after the severe recession it experienced up until 2013, it is expected that the rate of substitution of carbon intensive vehicles with new low emission ones will increase significantly in the following years.

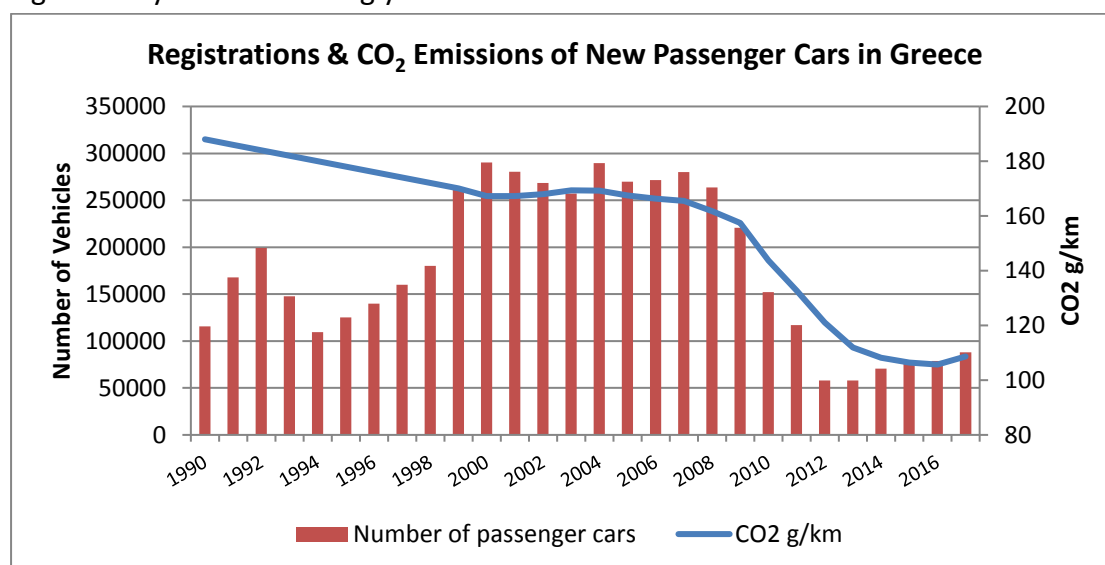

Figure 24 Figure Development of the Average CO₂ emissions emitted by the new passenger cars in Greece and the annual deployment of passenger cars (Sources: SEAA, ACEA).

NOTES: ¹ Average CO₂ Emissions of passenger cars sold prior to 2000 are hypothetical based on the technology of the most successful models in the market during the reference year. ²Cars sold prior to 2000 are found through ACEA databases and might have mismatches with the number of imported vehicles provided by SEAA.

⁶⁶The average mileage of Greek passenger car fleet was calculated on the basis of total petrol (gasoline) consumption for 2015, resulting to a total of 9,723 km/year

Table 6 Table CO₂ Emissions of Greece's passenger car fleet.

	Petrol Passenger Cars	Diesel Passenger Cars	Units
Annual Consumption / vehicle	671.976	498.563 ²	Liters
Combustion CO ₂ Emissions / liter ¹	2.39	2.67	CO ₂ kg/l
Annual CO ₂ Emissions / vehicle	1606.023	1331.163	CO ₂ kg
Total passenger fleet emissions	7.939	0.218	Mt CO ₂ eq

NOTES: ¹CO₂ equivalent emissions per liter of fueled combusted as estimated by US Environmental protection Agency ^{67,68}. ² The fuel consumption of diesel cars have been calculated based on a ratio of 0.74, which is a market statistics average of consumption ratio of diesel to petrol for the vehicles that have both petrol and diesel version [28]. Here is pointed that driving behavior per vehicle segment is required for more accurate data input.

The total emission resulting from the use of passenger cars are estimated to be 8.16 million tons of CO₂ equivalent, accounting for approximately 48.9% of the total emissions resulting from the activity of the transport sector in the Country. By substituting the older segment of the passenger car fleet with EVs we expect the tailpipe emissions of the total country's fleet to reduce radically. Such introduction, leads to 2.3% of tailpipe emission reduction (0.17 MtCO₂eq) for substitution of the 100 thousand most carbon intensive cars with EVs, while substituting the 1 million most carbon intensive passenger cars with EVs will result to 21.9%

Table 7 Table Tailpipe and Total Emission of Greek passenger car fleet in under various scenarios

Scenario	Reference	Number of EVs introduced by substitution of most carbon intensive cars			Units
		10,000	100,000	1,000,000	EVs
Average CO ₂ emissions per km	164.29	163.91	160.56	128.29	CO ₂ g / km
Total Fleet Tailpipe CO ₂ emissions	8.16	8.14	7.97	6.37	Mt CO ₂ eq/y
CO ₂ Tailpipe Emissions' Reduction (%)	0	0.2%	2.3%	21.9%	%
Total Indirect Emissions of EV segment of the passenger car fleet	0.02	7.70	76.96	769.60	kt CO ₂ eq/y
Total fleet emissions	8.16	8.15	8.05	7.14	Mt CO ₂ eq/y
CO ₂ Total Emissions' Reduction (%)	0%	0.1%	1.3%	12.5%	%

¹ The calculation of the tailpipe and indirect emissions CO₂ was based on the average mileage of Greek passenger car fleet calculated on the basis of total petrol consumption for 2015, resulting to a total of 9,723 km/year

² The reference EV model utilized in the scenario calculations was BMW i3 (2018)

³ Indirect emissions are calculated based on the carbon intensity of the local power sector of 582g CO₂/kWh

A. (ii) Reduction of carbon footprint of vehicles

Even though car production has been on the rise again since 2013, manufacturers have been able to decouple CO₂ emissions, energy consumption, water usage and waste generation from production growth. Total CO₂ emissions from car production,

⁶⁷ Ministry of Natural Resources Canada, (2014), "Learn the facts: Fuel consumption and CO₂"

⁶⁸ U.S. Environmental Protection Agency (EPA), (2011), "Greenhouse Gas Emissions from a Typical Passenger Vehicle",

for example, have remained stable despite a substantial increase in production volume – while CO₂ emissions per car produced dropped by 25.8% between 2007 and 2016. Such fact is expected also for the EV industry as it ramps up. In addition life cycle assessment science keeps monitoring the environmental proposition of the EV technology and pushes towards less carbon intensive manufacturing methods.

A. (iii) Avoided air pollutants in major cities.

The avoidance of major air pollutants emitted by the substituted conventional ICE vehicles in major cities is also of great significance. Air pollutants like non-methane hydrocarbons, CO, NO_x, SO_x and particulate matter (PM₁₀ and PM_{2.5}), responsible for environmental pollution, biodiversity disruption and effects on human health are now avoided and their emissions are decentralized towards carbon intensive power generation units, where their monitoring and mitigation are most effective.

A. (iv) Avoided water pollution

The conventional petroleum vehicles' use is indirectly responsible for the impact of the life cycle of its fuel. Petroleum production, refining, and distribution create significant risk of environmental contamination. For the oil products directed for consumption in the transport sector there is a significant amount lost in oil spills, which for 2017 was approximately 7,000 tons worldwide⁶⁹. In addition, refineries are estimated to generate 76 to 151 liters of wastewater for every barrel of petroleum refined⁷⁰. It is estimated that the passenger car fleet of Greece is indirectly responsible for the generation of 32.2 to 63.95 billion liters of waste water annually (2015) from the oil refinery process, indicating a high potential of waste water reduction resulting by the EV prevalence in the country.

A. (v) Mitigation of the noise pollution caused by on-road transport.

The European COMPETT project, launched by 5 partner institutes in Austria, Denmark and Norway, aiming to shed new light on the appropriate role of the government in the takeoff stage and the creation of a self-sustaining market for EVs, has elaborated a performance survey in regards to noise mitigation achieved by the substitution of conventional ICE vehicles with EVs. The survey study showed that EVs will have the potential to reduce the traffic noise in carparks and on streets where vehicles travel with speeds under 30 km/h.

⁶⁹ *The International Tanker Owners Pollution Federation Limited (ITOPF)*

⁷⁰ *C. Shulock, E. Pike A. Lloyd R. Rose, (2011), "Vehicle Electrification Policy study – Task 1 Report: Technology Status", ICCT*

B. EVs and the Decarbonization of on-road transport

Even though Electric Vehicles are promoted as a green solution for the transport sector, it is imperative that their introduction should be accompanied with power generation from RES. The carbon intensity of its power generation is the main indicator of how “green” are the EVs introduced to each energy system. Moreover, indirect CO₂ emissions caused by the use of electric vehicles can be significant in carbon intensive energy systems.

Greece’s power sector is one of the most carbon intensive ones among IEA countries with emissions that reached 582 grams of CO₂ per kWh produced in 2015, which is significantly higher than the average emissions of IEA member countries which were 390 gCO₂ per kWh in 2015. Even though, the carbon intensity of power generation of the country fell by 26% between 2005 and 2015, due to the greater deployment of renewable energy and natural gas and the decline of energy use due to recession, the introduction of EVs in such an electricity mix would not suggest a “green” transport solution.

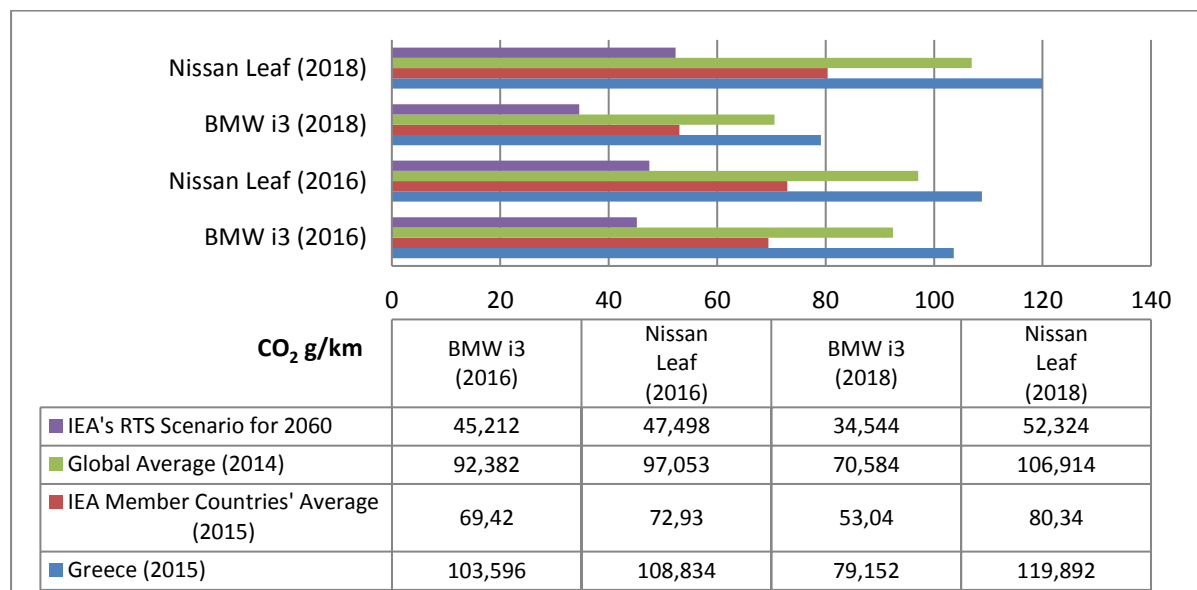

Figure 25 Indirect CO₂ Emissions of reference EVs in systems with different carbon intensity of electricity NOTE: ¹ For BMW i3 (2018) the fuel consumption and CO₂ emissions utilized in the formulation of this graph were determined in accordance with the measurement process as defined by European Regulation (EC) 715/2007 in the version applicable at the time of type approval.

Specifically, the deployment of two reference passenger EVs, the BMW i3 (94 Ah battery) (2016) with energy consumption and the standardized mixed driving cycle of 0.178 kWh/km and the Nissan Leaf (2016), which has achieved the most sales worldwide in 2016 and is one among the more widely successful vehicles in the worldwide EV market with consumption of 0.187 kWh/km are examined. Moreover, with the carbon intensity of Greece’s power system, the deployment of a BMW i3

would result in indirect emissions of 103.6 grams of CO₂ per km traveled, while in an average IEA country the same vehicle would emit only 69.4 g CO₂/km. In addition, a less efficient vehicle like Nissan Leaf (2015) would emit indirectly 108.8 grams of CO₂ per km traveled in Greece, which is similar to the emissions of a highly efficient small petrol vehicle or higher than a hybrid like Yaris hybrid by Toyota (2016), which emits 103.9 CO₂g/km⁷¹, while it would emit 72.9 g/km in an average IEA country.

7. Electric Vehicle introduction and Economic Repercussions in South East Europe

The automotive industry of the region mainly located in Turkey, Romania, Slovenia and Serbia has not yet made a significant turn in EV manufacturing. However, Turkey being one of the major auto-manufacturing economies of the region, producing more than 1.7 million vehicles per year while having nine R&D facilities which extend their operation beyond supporting the local industrial operation, has a lot of untapped potential is being an important market for the EV transition⁷². In Romania the prospect of Dacia, in producing a very cost-effective EV, while utilizing the underpinnings and the electric motor of Renault ZOE, thus exploiting the advantage of its participation in Renault-Nissan Alliance, is deemed very important for the acceleration of EV adoption in the region⁷³. South East Europe also has highly trained engineering professionals, who can help meet the requirements of EV R&D operations in the region. Significant, to that extent, is the fact that according to the Technical Chamber of Greece (TEE), there are 35,000 academically trained mechanical and electrical engineers currently active in the local labor market⁷⁴, who could help attract the automotive industry operators mainly in the fields of electrical motors, power systems electronics, traction control and information technology and networks.

The automotive component industry being a very significant economic activity in the region must also adapt to the EV transition. Significantly the regional markets segments associated with ICE Engines, transmission systems, fuel systems, exhaust, forging components and small general parts manufacturing are expected to be negatively affected by the transition to gearless, fuel-less, robust new vehicles. However, important segments of the regional manufacturing activity such as wiring, electric component development, electronic architecture systems and components

⁷¹ F. Munoz, (2018), "Brands with average CO₂ emissions between 110-130 g/km counted for 73% of European car regs in 2017", *JATO*

⁷² *Republic of Turkey – Ministry of Investment - Support and promotion Agency*

⁷³ M. Panait,(2017) "World's Cheapest EV Could Come From Dacia, Renault's Low-Cost Arm"

⁷⁴ *Technical Chamber of Greece (2018)*

and telematics are expected to attract new investors and expand their activity. Moreover the RES and electricity distribution industry is expected to be driven by electric mobility acceleration in the future with numerous new projects for new capacity installation and grid enhancement to facilitate “green” power to the electrified on-road transport.

Bibliography

- *International Energy Agency (IEA)*, (2017), “Global EV outlook 2017”, *OECD/IEA 2017*, Available online at:
<https://www.iea.org/publications/freepublications/publication/GlobalEVOutlook2017.pdf>
- *International Energy Agency (IEA)*, (2017), “Energy Technology Perspectives 2017 - Catalysing Energy Technology Transformations”
- E. A. Olivetti et al. (2017), “Lithium-Ion Battery Supply Chain Considerations: Analysis of Potential Bottlenecks in Critical Metals” *Joule*, v. 1, issue 2, p. 229-243
- *Benchmark Mineral Intelligence* (2017)“Rise of the lithium-ion battery Megafactories: What does 2018 Hold”, Available online at:
<http://benchmarkminerals.com/where-is-new-lithium-ion-battery-capacity-located/>
- N. Igglezou , N Chatziargiriou, (2013), “Operation analysis and Modelling of Capacitors” – Diploma Thesis (in Greek), *NTUA*
- P. Hertzke, N. Müller, and S. Schenk, (2017),“China’s electric-vehicle market plugs in”, *McKinsey & Company*, *Article: McKinsey Quarterly*, Available online at:
<https://www.mckinsey.com/global-themes/china/chinas-electric-vehicle-market-plugs-in>
- McKerracher, (2017), “EV market trends and outlook – Shift up a gear”. *Bloomberg New energy Finance*, Presentation available online at:
<https://www.transportenvironment.org/sites/te/files/EV%20market%20trends%20and%20outlook%20%28by%20Colin%20McKerracher%29.pdf>
- *IHS Markit*, (2017), “The Future of Cars 2040: Miles Traveled Will Soar While Sales of New Vehicles Will Slow, New IHS Markit Study Says”, *Press Release*, Available online at:
<http://news.ihsmarkit.com/press-release/energy-power-media/future-cars-2040-miles-traveled-will-soar-while-sales-new-vehicles->
- J. Mac Donald, (2016),“Electric Vehicles to be 35% of global new car sales by 2040”, *Bloomberg New Energy Finance*, Available online at:
<https://about.bnef.com/blog/electric-vehicles-to-be-35-of-global-new-car-sales-by-2040/>

- *Greek Government Gazette*, (2017), “National Policy Framework on alternative fuels”, v. 3824, 2nd issue p. 46463 – 46550, Available online at: <https://www.maritimes.gr/news/uploads/YEN/171115%20National%20Policy%20Framework%20on%20alternative%20fuels.pdf>
- Soulopoulos, (2017), “When Will Electric Vehicles be Cheaper than Conventional Vehicles?” Bloomberg New Energy Finance, Executive Summary available online at: <http://www.automotivebusiness.com.br/abinteligencia/pdf/EV-Price-Parity-Report.pdf>
- *International Electrotechnical Commission (IEC)*, (2010), “IEC 61851-1:2010” | IEC Webstore [Online]; [cited 2018 Jan 29]. Available online at: <https://webstore.iec.ch/publication/6029>
- *International Electrotechnical Commission (IEC)*, (2014), “IEC 62196: (a) IEC 62196-1:2014” “Plugs, socket-outlets, vehicle connectors and vehicle inlets - Conductive charging of electric vehicles - Part 1: General requirements”, (b) IEC 62196-2:2016 “Plugs, socket-outlets, vehicle connectors and vehicle inlets - Conductive charging of electric vehicles - Part 2: Dimensional compatibility and interchangeability requirements for a.c. pin and contact-tube accessories”, (c) IEC 62196-3:2014 “Plugs, socket-outlets, vehicle connectors and vehicle inlets - Conductive charging of electric vehicles - Part 3: Dimensional compatibility and interchangeability requirements for d.c. and a.c./d.c. pin and contact-tube vehicle couplers”, Content analysis available online at: https://wiki2.org/en/IEC_62196
- *International Electrotechnical Commission (IEC)*, (2011), “A step forward for global EV roll-out : IEC International Standard for EV charging”, *News release – 2011 n. 04*, Available online at: <http://www.iec.ch/newslog/2011/nr0411.htm>
- *International Energy Agency (IEA)*, (2017), “Energy Policies of IEA Countries – Greece 2017 Review”, Available online at: <https://www.iea.org/publications/freepublications/publication/EnergyPoliciesofIEACountriesGreeceReview2017.pdf>